

# RGD Motor-tuned Model 722

Five valve, plus rectifier and tuning indicator, three wave-band motor and manually tuned table superhet for 200-250 volt, 50-100 cycle supplies, price 22 gns.

### CIRCUIT OUTLINE

**C**OUPLED circuits selected by a two wipe switch form the input to the first valve, V1, a HF pentode, controlled by AVC. Similar pairs of circuits couple V1 to the grid circuit of V2, a triode hexode mixer, again provided with AVC.

Permeability tuned intermediate frequency transformers are used, IFT1 having optional coupling for increasing the band width. The oscillator section of V2 utilises tuned anode connections.

Intermediate amplification is carried out by V3, a further variable-mu pentode with AVC. The secondary of IFT2 works into the signal diode of V4, a double diode triode, the other diode being used for AVC. A simple filter is used between the diode load and the volume control.

Coupling to the output valve, V5, is

by resistance and capacity. This is an AC/4 Pen and has a feedback connection to the cathode circuit of the triode.

Power supply is obtained from V7, a full wave rectifier, in conjunction with the field coil of the speaker and the usual electrolytic condensers.

Other features include an electronic tuning indicator, V6, fed from the diode load and the tuning motor. This is of the reversible AC "homing" type operated by the usual buttons and contact discs. Provision for remote control is arranged for by a multiple socket which can be connected to a long cable terminating in a row of further buttons. There is also the usual lamp for setting up the buttons.

### Wavechange Switches.

Switching is carried out by means of three wafers each carrying two wipes. The drawing shows the effective contacts on each wafer, but earthing is automatically introduced by a further wipe.

The first wafer, farthest from the click plate, carries wipes 1 and 2 which control the aerial circuits.

The second and third wafers are back to back with an interposed screen and

(Continued on page 6.)

Right, the switch banks with wipes and contacts numbered as in the circuit. Refer also to notes under "Wavechange Switches" in text on this page.

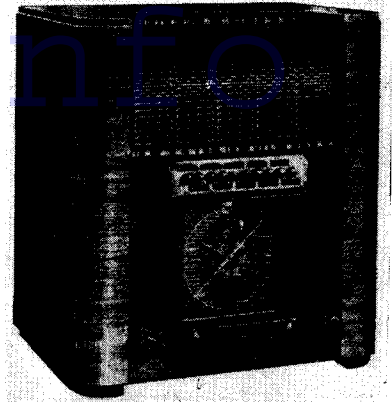
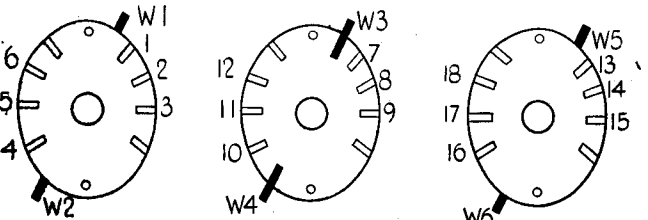

### CONDENSERS

	Mfd.s.
1 .. SW HF top coupling ..	.000005
2 .. LW osc. fixed trimmer ..	.000026
14 .. LW fixed padder ..	.000145
15 .. MW fixed padder ..	.000465
16 .. AVC coupling ..	.00005
17 .. V1 grid coupling ..	.00015
18 .. V2 grid coupling ..	.00015
19 .. Osc. anode coupling ..	.0001
20 .. Osc. grid coupling ..	.0001
21 .. HF filter ..	.0001
22 .. HF filter ..	.0001
23 .. V5 anode shunt ..	.001
24 .. LF speech coupling ..	.001
25 .. SW fixed padder ..	.003
26 .. LF coupling ..	.01
27 .. V4 anode LF shunt ..	.04
28 .. V3 AVC decouple ..	.04
29 .. TI input shunt ..	.04
30 .. V1 anode decouple ..	.1
31 .. V2 anode decouple ..	.1
32 .. V3 anode decouple ..	.1
33 .. LF coupling ..	.1
34 .. V1 and V2 AVC decouple ..	.1
35 .. V2 screen decouple ..	.1
36 .. V1 screen decouple ..	.8
37 .. HT smoothing ..	.8
38 .. HT smoothing ..	16
39 .. V4 cathode shunt ..	50
40 .. V1 screen bypass ..	.1

### VALVE READINGS

V.	Type.	Electrode.	Volts.
1 ..	AC/VP2 (Mazda)	Anode .. Screen ..	250 200
2 ..	AC/TH1 (Mazda)	Anode .. Screen .. Osc. anode	235 100 85
3 ..	AC/VP2 (Mazda)	Anode .. Screen ..	245 200
4 ..	TDD4 (Mullard)	Anode ..	115
5 ..	AC/4 Pen (Mazda)	Anode .. Screen ..	245 255
6 ..	TV4A (tuning indicator) (Mullard)		
7 ..	UU4 (Mazda)	Heater ..	340

Pilot lamps .. 6.2v. 300 ma. Tubular MES

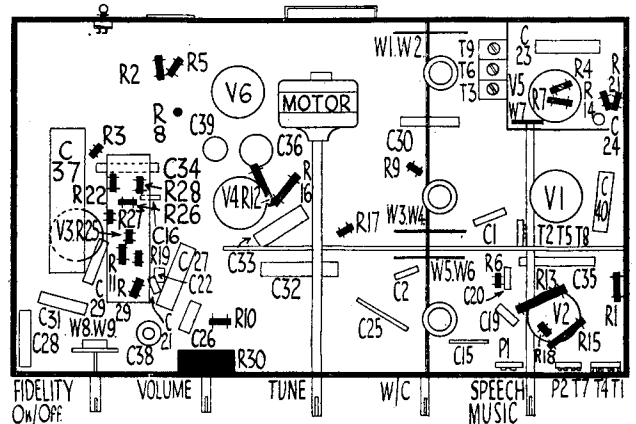
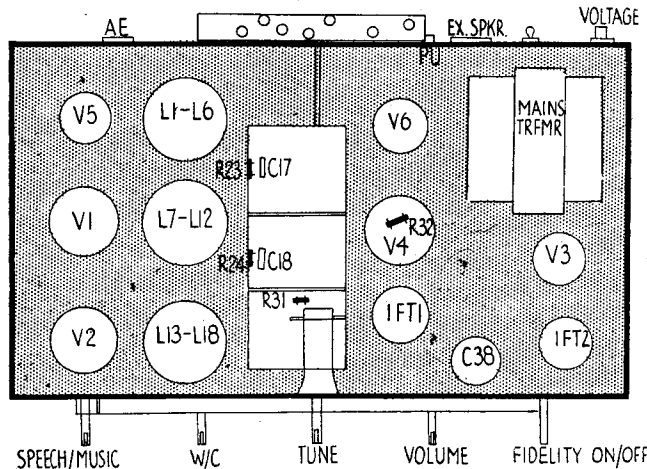

Components on the chassis can be identified with the aid of these diagrams of the top (left) and underside. The motor tuning adds little complexity, the set being basically orthodox.

For more information remember  
www.savoy-hill.co.uk

# 10-MINUTE FAULT-FINDER

# RGD 722

**Power Test.**—The object of this test is to ensure that the main HT and output circuits are correct.

The italic letters below refer to test points shown in the circuit diagram. Points *A* and *B* are located at pins 2 and 3 on the speaker plug. All voltage measurements are with respect to chassis.

Voltagess : *A*, 340; *B*, 260.

Resistance : *A-B*, 700 ohms.

Total feed =  $340 - 260 \div 700 = 114$  ma.

As each of the following injection tests proves correct, proceed at once to the next stage.

**Output Stage, V5.**

Inject 2 volts AF V5 grid. If defective, check :—

Voltagess : *C*, 245; *D*, 255.

Resistances : *C-B*, 50; *F-E*, 125,000 ohms.

**AF Stage, V4.**

Inject .5 volt V4 grid. If defective, check :—

Voltage : *G*, 115.

Resistances : *G-B*, 40,000 ohms; *H-E*, 2.25 megohms.

**Demodulation.**

Inject strong 465 kc. signal V3 anode. If defective, check :—

Resistances : L21, 8; L22, 9; *H-E*, 540,000 ohms.

**IF Stage, V3.**

Inject 465 signal V3 grid. If defective, check :—

Voltagess, *I*, 245; *J*, 200.

**Hexode, V2.**

Inject 465 kc. signal V2 anode. If de-

fective, check :—

Resistances : L9, 14; L20, 13 ohms; *K-E*, 1.2 megohms.

Inject 465 kc. signal V2 grid. If defective, check :—

Voltagess : *L*, 235; *M*, 200.

If no signals are received, connect aerial to V2 grid through 5 mmfd. If still no signals, check :—

Voltage : *O*, 85. Resistances : *O-B*, 40,000; *P-E*, 50,000 ohms.

**RF Stage, V1.**

If signals are obtained with aerial on V2 grid and not on input, check :—

Voltagess : *Q*, 250; *S*, 200.

Resistances : *Q-B*, 1,000 ohms; *N-E*, 1.7 megohms; *T-E*, 1.7 megohms.

If still no signals, check pre-selector circuits and switches.

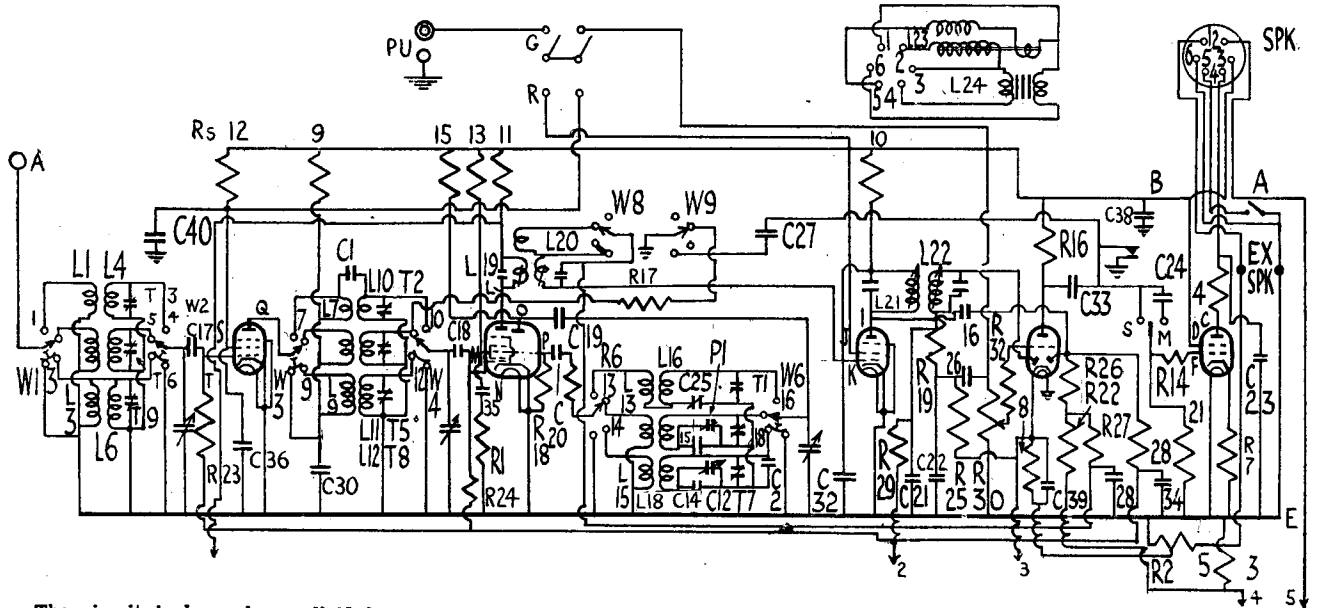

The circuit is here shown divided solely for presentation reasons. Disregarding the motor switching, the circuit is straightforward.

**WINDINGS**

(D.C. Resistances)

L.	Ohms.	Range.	Where measured.
1	2	SW	W1 and earth.
2	34	MW	W1 and earth.
3	72	LW	W1 and earth.
4	V. low	SW	Across aerial gang.
5	5	MW	Across aerial gang.
6	22	LW	Across aerial gang.
7	1.8	SW	W3 and C30.
8	1.1	MW	W3 and C30.
9	1.4	LW	W3 and C30.
10	V. low	SW	Across HF gang.
11	5	MW	Across HF gang.
12	21	LW	Across HF gang.
13	V. low	SW	W5 and C25.
14	1.8	MW	W5 and earth.
15	3	LW	W5 and earth.
16	V. low	SW	W5 and C25.
17	3.5	MW	W6 and C15.
18	14	LW	Inaccessible.
19	14	—	V2 anode and C40 + R11.
20	13	—	V3 grid and C28 + R27.
21	8	—	V3 anode and C32 + R10.
22	9	—	V4 signal diode and R19 + R25.
23	700	—	Pins 2 and 3 on speaker plug.
24	210	—	Pins 3 and 4 on speaker plug.
25	15	—	Mains plug.

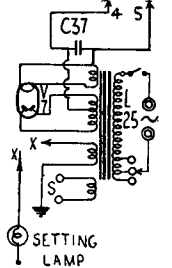
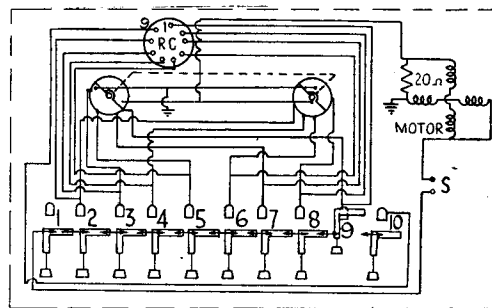
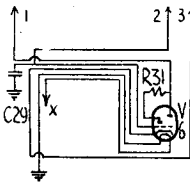

**RESISTANCES**

	Ohms.
2	Feed back pot. (part) .. 20
3	Delay bias .. 28
4	V5 anode stabiliser .. 50
5	Feed back pot. (part) .. 60
6	Het. volt control .. 100
7	V5 cathode bias .. 115
8	V4 cathode bias .. 700
9	V1 anode decouple .. 1,000
10	V3 anode decouple .. 1,000
11	V2 anode decouple .. 6,500
12	V1 screen decouple .. 10,000
13	V2 screen feed .. 25,000
14	V5 grid stopper .. 25,000
15	Osc. anode load .. 40,000
16	V4 anode load .. 40,000

**Resistances (continued)**

17	MW HF shunt (fidelity) .. 50,000
18	Osc. grid leak .. 50,000
19	HF filter .. 50,000
21	V5 grid leak .. 100,000
22	AVC diode load (part) .. 200,000
23	V1 grid return .. 490,000
24	V2 grid return .. 490,000
25	Signal diode load .. 500,000
26	AVC diode load (part) .. 500,000
27	V3 AVC decouple .. 1 meg.
28	V1 and V2 AVC decouple .. 1 meg.
29	TI feed .. 2 meg.
30	Volume control .. 2 meg.
31	TI anode feed .. 2 meg.
32	V4 grid stopper .. 250,000

# RGD Motor-tuned 722

(Continued from page 2.)

control the HF circuits and the oscillator coils respectively.

## CONSTRUCTIONAL FEATURES

**EVERYTHING** is perfectly orthodox and calls for no particular comment.

A rather unusual feature, perhaps, is the crossing from one side of the chassis to the other in the valve sequence, followed by a return to the output valve which is mounted next to the first valve. This point should be borne in mind when making routine valve test measurements, as otherwise it is easy to mistake the valve positions.

It should be noted that the fidelity position is governed not only by the coupling of the first transformer, but also the damping of the MW HF coil. The switching also provides for the connection of a further shunt condenser on the anode circuit of V4.

In this chassis a special switch is provided for reducing the bass output on speech by means of a smaller coupling condenser.

Provision is made for aerial and earth connections, external speaker and pick-up. There is also a multiple socket for the remote control plug board and provision for silencing by switching the internal and external speakers.

## Chassis Removal.

All the knobs are held by self-tapping screws which bite into the split control shafts. It is preferable to remove the screws from the knobs as this allows them to be withdrawn quite easily.

The chassis is held in the cabinet by means of bolts and T nuts. The speaker connection is made by a multiple plug

and socket. It is necessary, however, to dismantle the press-button assembly if it is desired to separate the chassis from the cabinet. The method is as follows:—

First release the knurled-headed bolts at the corners of the escutcheon. If no tool is available for this purpose, they can be released by gently tapping the end of a small screwdriver, the blade of which is placed in the knurling. Hold the end of the blade so that it cannot slip out of the knurling and scratch the cabinet. Then remove the two bolts holding the switch button unit.

## Alignment

### IF Circuits (Frequency 465 kcs.)

Connect an output meter to the set and the generator to the grid of V2 and inject a signal of 465 kcs., using a low value below the AVC level.

The transformers are permeability tuned and are brought to resonance by slight adjustment of the cores in the normal manner.

### Short Waves (16.5-50 metres.)

Connect generator through the dummy aerial to the set terminals and tune set and generator to 16.5 metres and adjust T1, T2 and T3 for maximum in that order.

Check the alignment at 50 metres.

### Medium Waves (195-550 metres.)

Tune set and generator to 200 metres and adjust T4, T5 and T6 for maximum in that order.

Tune set and generator to 550 metres and adjust P1 for maximum, simultaneously rocking the gang.

Repeat the sequence of operations until no improvement results.

### Long Waves (800-2,000 metres.)

Tune set and generator to 857 metres, and adjust T7, T8 and T9 for maximum.

Tune set and generator to 2,000 metres and adjust P2, simultaneously rocking the gang.

Repeat the sequence of operations until no improvement results.

## Automatic Tuning

**TUNE** in the desired station manually. Remove the red plug from its socket at the back of the chassis. Remove the white plug from the contact socket and replace it by the black plug from socket at back of chassis. This will cause the setting lamp to light.

Slacken the knurled locking screw on the contact and slide it round the track until the lamp is extinguished. Then lock up the contact making sure the springy arm lies correctly on the disc, and return the plugs to their previous positions.

The contacts are identified in relation to their respective push-buttons by colour coded leads which are as follows. (The buttons are numbered from left to right, the first and last, however, operating remote control and manual tuning, do not have contacts and are, therefore, omitted from the series.)

Button.	Lead.	Tracer.	Button.	Lead.	Tracer.
(1)	Black	White	(5)	White	Green
(2)	Blue	Green	(6)	White	Blue
(3)	White	Black	(7)	Black	Red
(4)	White	Red	(8)	Red	Black

## Replacement Condensers

**EXACT** replacement electrolytic condensers for the R.G.D. model 722 are available from A. H. Hunt, Ltd., of Bendon Valley, Garratt Lane, Wandsworth, London, S.W.18

For C37 there is unit list number 1922A, price 4s. 6d., and for C38, unit 2530A, 6s. 6d. For C39 there is unit 1079, 2s. 3d., and for C36, unit 4286, price 4s. 6d.

# G.E.C. 4050 Push-button Five

(Continued from page 4.)

the ordinary tuning knob at the side. When it is accurately tuned depress the button on which it is desired the station shall appear to its fullest extent. Then relock the shaft screw.

Test the accuracy of the adjustment by operating the press-button.

If there is any slight error the adjustment operation must be repeated.

## Alignment

### IF Circuits (Frequency 456 kcs.)

Tune set to maximum on LW and tone to brilliant. Short oscillator gang and connect generator to V1 grid through a .1 mfd. condenser with output meter connected to the speaker terminals.

Adjust T12, T11, T10 and T9, using a low input always below the AVC value.

### Medium Waves (192 to 550 metres.)

Connect the generator through a dummy aerial to the input of the set and tune set and generator to 1,400 kcs. (214 metres) and adjust T2 and T5 for maximum

In order to adjust the padder condenser, unsolder the wire from the side of the oscillator gang and substitute an external tuning condenser between this lead and chassis. Inject from the generator a frequency of 600 kcs. (500 metres) and simultaneously adjust the external tuning

Top "deck" layout diagram showing valve and two trimmer positions. Under-side layout is on page 4.

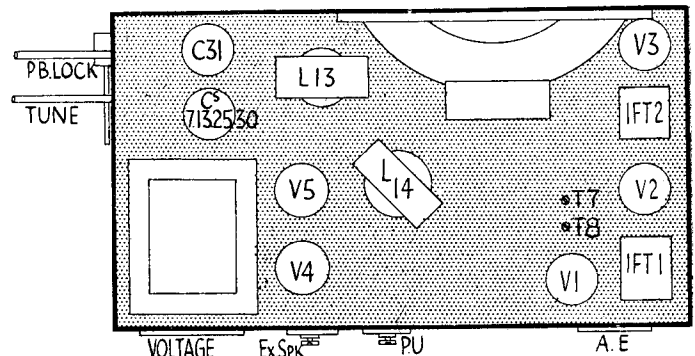

condenser and the set tuning control for maximum.

Then resolder the lead to the oscillator gang, and without altering the tuning position adjust P1 until the same maximum output is obtained.

Then re-check the trimming at 1,400 kcs.

### Long Waves (1,000 to 2,000 metres.)

Tune set and generator to 300 kcs. (1,000 metres) and adjust T3 and T6 for maximum.

Then adjust the padding at 165 kcs. (1,818 metres) using an identical process with that for the medium band, finally adjusting P2 after re-connecting the oscillator gang.

Re-check the trimming at 500 kcs.

### Short Waves (16.5 to 50 metres.)

Tune set and generator to 18 mcs. (16.7 metres) and adjust T4 and T1 for maximum using the lowest capacity on T4 which gives a peak.

If pulling is experienced, slightly rock the gang.

## Replacement Condensers.

**EXACT** replacement electrolytic condensers for the G.E.C. model 4050 are available from A. H. Hunt, Ltd., Bendon Valley, Garratt Lane, Wandsworth, London, S.W.18.

For the unit containing Cs 7, 30, 13, and 25, there is type 1,529, list price 9s. 6d.; for C31, unit 2,516A, 6s., and for C22, unit 4,033, price 2s.