

R.G.D. 175, 245, 395, 455

Four-valve, plus rectifier, three waveband table, console and radio-gram models with pre-set push-button tuning and for A.C. mains operation. Made by the Radio Gramophone Development Co., Ltd., Globe Works, Newtown Row, Birmingham.

Circuit.—The aerial is connected through an I.F. filter to coupled circuits energising the grid of V1, the frequency-changer. A.V.C. is applied direct to the grid, C2 being a D.C. stopper. The oscillator circuit is tuned anode, with

permeability coils, and simple coupling windings in the grid.

Five station-selecting push-buttons connect pre-set condensers into the aerial circuit and permeability coils into the oscillator circuit. Permeability trimmed I.F. transformers lead to V2, the I.F. amplifier, and V3, the double-diode-triode.

Both demodulation and A.V.C. are provided by one diode, and a push-button controlled pick-up connection is provided. The triode section is biased from the A.V.C. line on radio and by grid current through the high value leak on gram.

V3 is resistance-condenser coupled to V4, the output tetrode, an unusual feature of which is a muting switch, operated by the P.B. release bar, and connected across the grid circuit.

There are fixed and variable tone circuits connected to the anode of V4.

V5 is a conventional full-wave rectifier with the speaker field and two electrolytics for smoothing.

WAVEBANDS: 16.5-50, 195-550, 800-2,000 metres. Average consumption, 75.8 v.a. Provision for low-impedance extension speaker.

GANGING

I.F. CIRCUITS.—Inject 465 kc. first to V2 grid-then to V1 grid, adjusting the cores of the I.F. transformers for maximum.

A non-metallic adjusting tool must be used, and care should be taken not to screw a core beyond the limit of its thread. Reduce the input as the circuits come into line to prevent A.V.C. working.

L.W. BAND.—Dial to and inject 1,000 m. Adjust T1 and T2.

Dial and inject 2,000 m. and adjust T3. Repeat adjustments.

M.W. BAND.—Dial to and inject 200 m. Adjust T4 and T5.

Dial and inject 500 m. and adjust T6. Repeat adjustments.

S.W. BAND.—Dial and inject 16.5 m., adjust T7 and T8.

Dial and inject 50 m. and adjust T9. Repeat adjustments.

I.F. REJECTOR.—Tune to 1,000 m. and inject 465 kc. to aerial. Adjust T10 for minimum.

PUSH-BUTTONS

The adjusting screws are below the P.B. escutcheon. There are aerial and oscillator trimmers associated with each button, the aerial trimmers being the top ones.

Aerial trimmers are turned anti-clockwise to increase wavelength, and oscillators are turned clockwise.

Select button with suitable wave range, wait till set has warmed up, set aerial trimmer midway.

Then adjust first oscillator, then aerial trimmers for maximum, checking against the station as received manually. This is best done on the customer's aerial.

This R.G.D. set is a fairly conventional four-valve plus rectifier model with pre-set automatic tuning circuits. The trimmers shown on the chassis layout diagram are actually accessible from the front and from underneath.

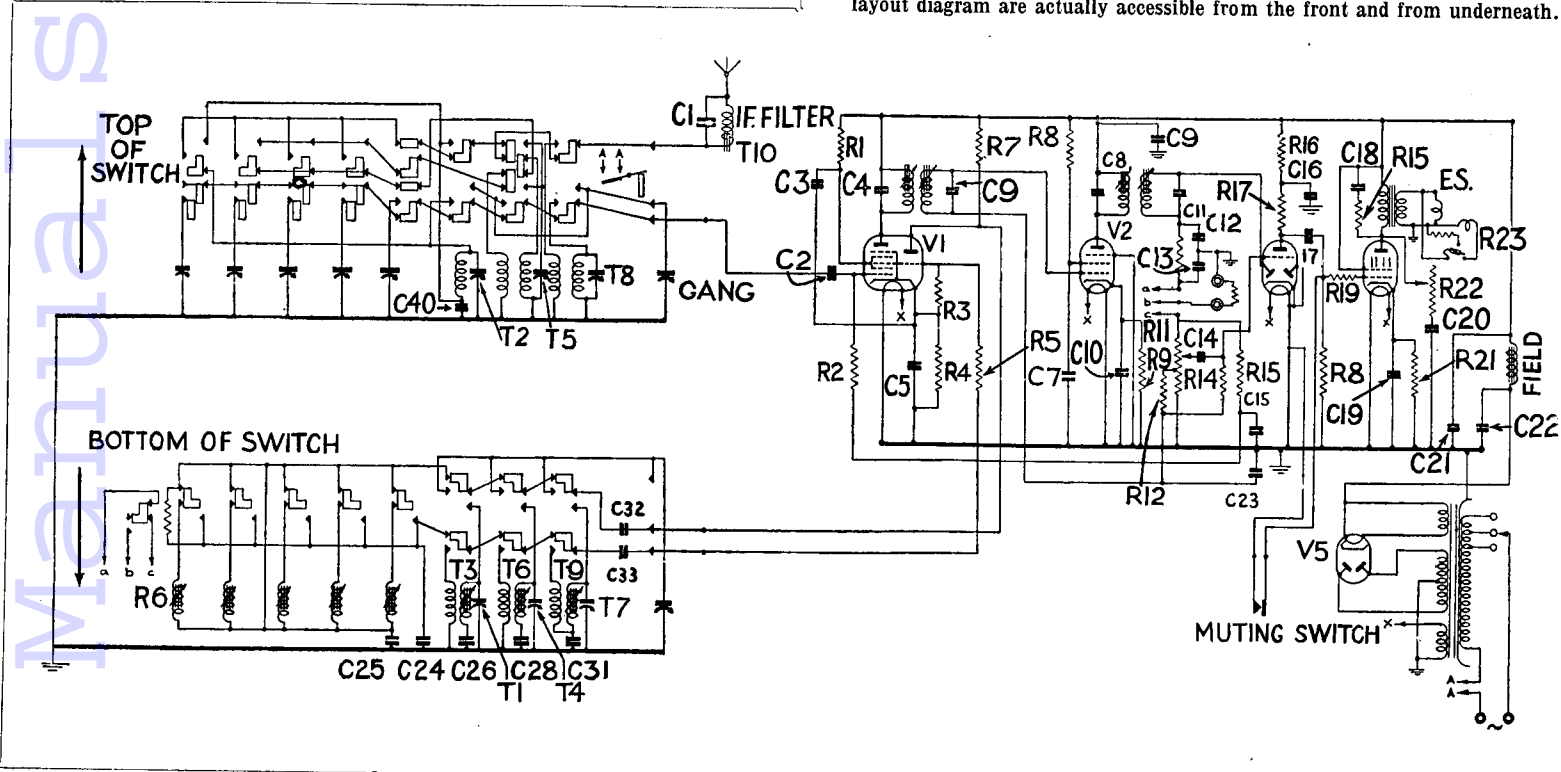
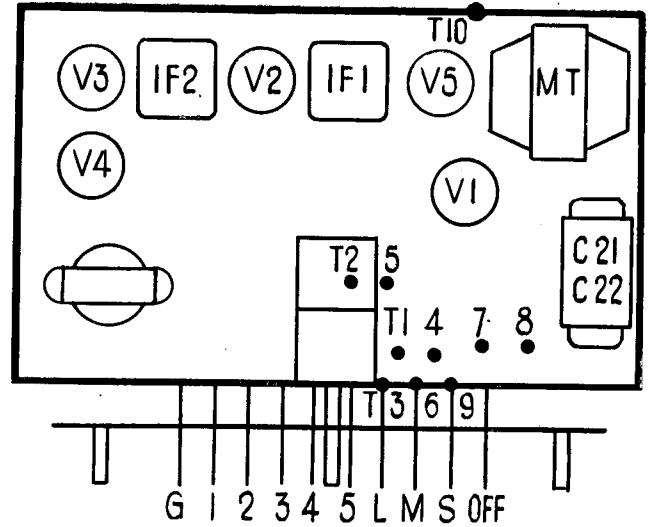

VALVE READINGS

V.	Type.	Electrode.	Volts.	Ma.
1	TH41	Anode	275	—
		Screen	75	—
		Osc anode 75(M, L,W)55(SW)		—
		Cathode	2.1	—
2	VP41	Anode	275	—
		Screen	200	—
		Cathode	2.8	—
3	HL42DD	Anode	55	2.8
4	Pen. 45	Anode	250	46
		Screen	260	—
		Cathode	9	—
5	UC6	Anodes	320	—
		Cathode	380	—

Pilot lamps, 6.2v. 3 amp.

RESISTANCES

R	Ohms.	R	Ohms.
1	25,000	13	50,000
2	5 meg.	14	2 meg.
3	50,000	15	2 meg.
4	200	16	20,000
5	100	17	50,000
6	20,000	18	5 meg.
7	40,000	19	5,000
8	25,000	20	5,000
9	270	21	180
10	100,000	22	25,000
11	5 meg.	23	5
12	1 meg.	Field	1,200

CONDENSERS

C	Mfds.	C	Mfds.
1	200 mmfds.	17	.04
2	.0001	18	.001
3	.1	19	50
4	200 mmfds.	20	.1
5	.04	21	16
6	200 mmfds.	22	16
7	.1	23	.1
8	200 mmfds.	24	370 mmfds.
9	.1	25	800 mmfds.
10	.04	26	160 mmfds.
11	200 mmfds.	28	190 mmfds.
12	150 mmfds.	31	4,000 mmfds.
13	100 mmfds.	32	.0001
14	.01	33	.0001
15	.04	40	.01
16	8		