

McMICHAEL TWIN-SPEAKER SUPERHET

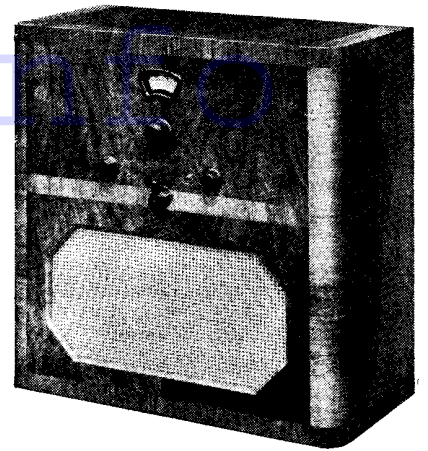

The Twin-speaker Superhet by McMichael Radio, Ltd., is a "de luxe" type of table receiver for A.C. mains operation.

Circuit.—The combined first detector oscillator valve, AC/TP met. (V1), is preceded by a single tuned aerial circuit which is coupled to a special input filter. The oscillator circuit is conventional for an H.F. pentode triode valve and coupling to the next valve is by band-pass I.F. transformer (for frequency see special notes). Bias for the pentode section is by A.V.C. and cathode resistance.

The first I.F. valve, AC/VP1 met. (V2), is coupled to a second I.F. valve, which is another AC/VP1 met. (V3), by a second band-pass I.F. transformer and V3 is similarly coupled to the second detector.

An AC/HL met. (V4) operates as a muting valve on radio and a first L.F. amplifier on pick-up reproduction.

The output valve is an AC/2Pen/DD (V5) which is stabilised by a grid resistance and tone compensated by a condenser between the anode and cathode as well as by tone control condenser and resistance.

Mains equipment consists of transformer with H.F. by-pass condensers, voltage doubler rectifier and a 1,200-ohm speaker

field in the positive H.T. lead for smoothing.

The 7,500-ohm field of the other speaker is in series with a 1,500-ohm resistance across the smoothed H.T.

Special Notes.—There is a sensitivity switch at the back of the chassis.

The first models of this receiver used an intermediate frequency of 406-410 kc. but later models are tuned to 428 kc. These models are marked by a splash of orange paint on the I.F. transformer cans.

Where several "whistles" are encountered on the first models the I.F. frequency may be increased to 428 kc. This involves retracking the oscillator and (in the case of early models which have orange and blue tracking condensers mounted underneath

(Continued on opposite page.)

VALVE READINGS

No signal. Full sensitivity (switch down).

| Valve. | Type. | Electrode. | Volts. | M.a. |
|--------|-------------------|------------|--------|------|
| 1 | A.C./TP met. (9) | anode | 215 | * |
| | | aux. grid | 170 | |
| | | osc. anode | 112 | |
| 2 | A.C./VP1 met. (7) | anode | 250 | 3.9 |
| | | aux. grid | 150 | |
| 3 | A.C./VP1 met. (7) | anode | 250 | 3.9 |
| | | aux. grid | 150 | |
| 4 | A.C./HL met. (5) | anode** | 250 | 37 |
| | | aux. grid | 240 | 6 |

* Set is unstable with long meter leads for current tests.
** Very high resistance in circuit, no appreciable voltage will be recorded.

RESISTANCES

| R. | Purpose. | Ohms. |
|-----|-----------------------------------|-------------|
| 1 | Harmonic suppressor V1 osc. grid. | 2,000 (1) |
| 2 | Series with V1 suppressor grid. | 2,000 (1) |
| 3 | Decoupling V1 grid | .5 meg (3) |
| 4 | Part of V1 aux. grid ptr. | 10,000 (1) |
| 5 | Part of V1 aux. grid ptr. | 20,000 (1) |
| 6 | Decoupling V1 anode | 10,000 (1) |
| 7 | Decoupling V1 osc. anode | 50,000 (1) |
| 8 | V2 cathode bias | 500 (1) |
| 9 | Decoupling V2 grid | .5 meg (3) |
| 10 | V2 and V3 cathode bias | 1,000 (1) |
| 11 | V3 cathode bias | 500 (1) |
| 12 | Part of A.V.C. ptr. | 2 meg (3) |
| 13 | Decoupling V3 grid | .5 meg (3) |
| 14 | Part of A.V.C. ptr. | .5 meg (3) |
| 15 | H.F. stopper from diode | 100,000 (3) |
| 16 | Diode load | 250,000 (3) |
| 17 | Part of bias ptr. | 140 (1) |
| 18 | V5 grid stabiliser | 50,000 (1) |
| 19 | Voltage control of V4 | .5 meg (3) |
| 20 | Part of bias ptr. | 500 (1) |
| 21 | Part of bias ptr. | 50 (1) |
| 22 | V1 osc. grid leak | 50,000 (1) |
| 23* | Across P.U. connections | 20,000 (1) |
| 24 | V5 anode stabiliser | 50 (1) |
| 25 | Voltage drop to L.S. field 2 | 1,500 (2) |
| | L.S. No. 1 field | 1,200 |
| | L.S. No. 2 field | 7,500 |

Bracketed figures denote wattage.
* Used only in models with P.U. sockets instead of jacks.

CONDENSERS

| C. | Purpose. | Mfd. |
|----|--|------------|
| 1 | Decoupling V1 grid | .03 (450) |
| 2 | Decoupling V1 anode | .1 (450) |
| 2A | Decoupling V1 grid | .01 (450) |
| 3 | Decoupling V1 osc. anode | .1 (450) |
| 4 | Decoupling V1 aux. grid | .1 (450) |
| 5 | Decoupling V2 grid | .03 (450) |
| 6 | V2 cathode | .1 (375) |
| 7 | V3 cathode | .1 (375) |
| 8 | Decoupling V3 grid | .03 (450) |
| 9 | Decoupling A.V.C. line | .001 |
| 10 | IF feed to A.V.C. diode | .0001 |
| 11 | H.F. by-pass from diode | .0001 |
| 12 | V5 cathode | .25 (25) |
| 13 | Tone control circuit | .05 (450) |
| 14 | L.F. coupling to V5 grid | .002 |
| 15 | V4, V5 L.F. coupling on gram. | .01 |
| 16 | V1 cathode | .0002 |
| 17 | V1 osc. grid reservoir (or .0005) | .0002 |
| 18 | Balancing condenser for aerial filter. | .0003 |
| 19 | Balancing condenser for aerial filter. | .0002 |
| 20 | V2, V3 aux. grid by-pass | .5 |
| 21 | H.T. smoothing | 8 (440) |
| 22 | H.T. smoothing | 8 (440) |
| 23 | Tone compensating V5 anode | .002 (450) |
| 24 | Voltage doubler condenser | 4 (400) |
| 25 | Voltage doubler condenser | 4 (400) |
| 26 | H.F. by-pass from mains | .002 (450) |
| 27 | H.F. by-pass from mains | .002 (450) |

Bracketed figures denote working voltages.

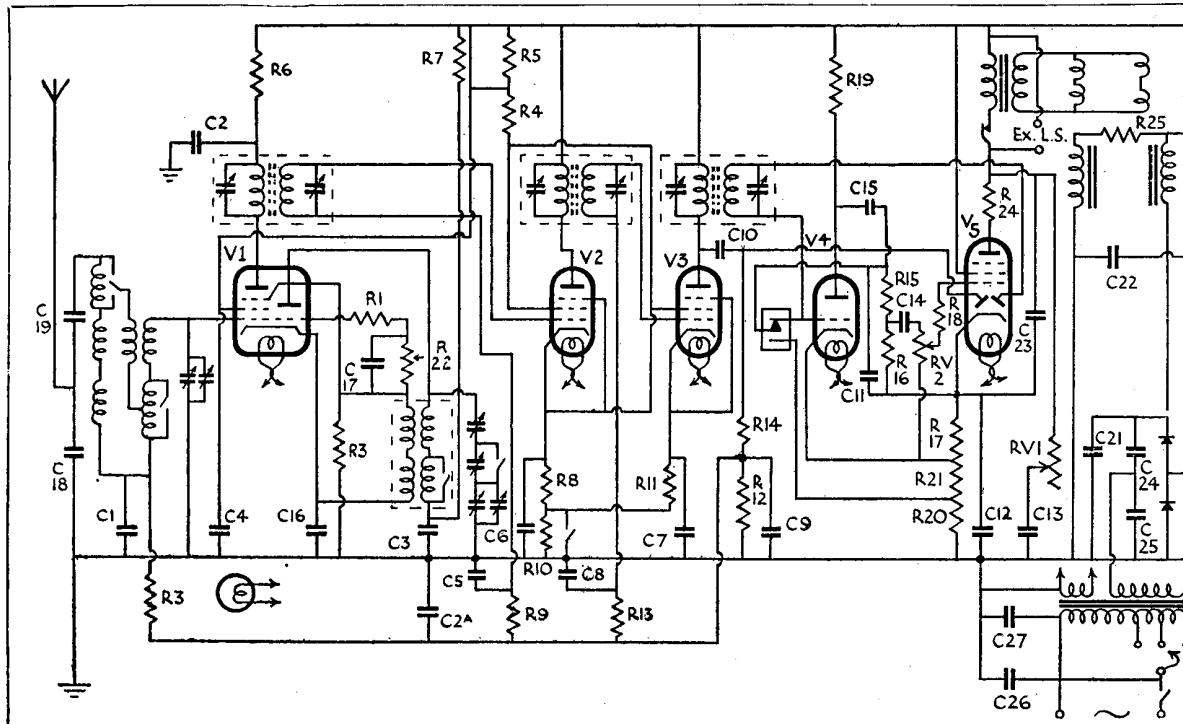

The McMichael circuit is designed round a triode - pentode frequency-changer, two intermediate frequency amplifiers, a muting valve and a combined double-diode and pentode valve.

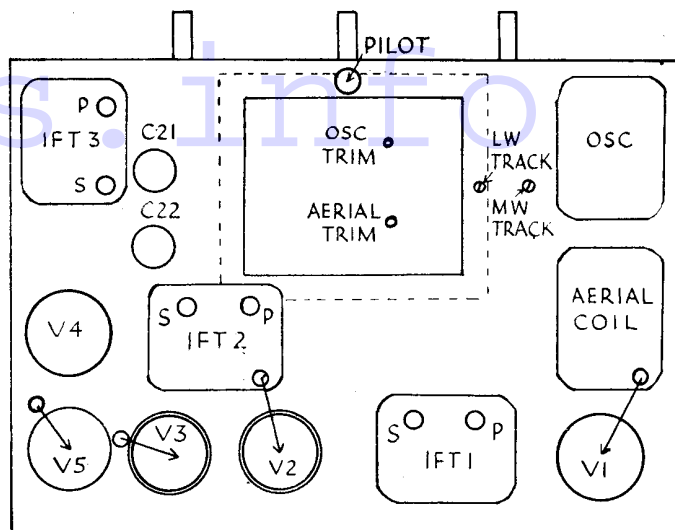
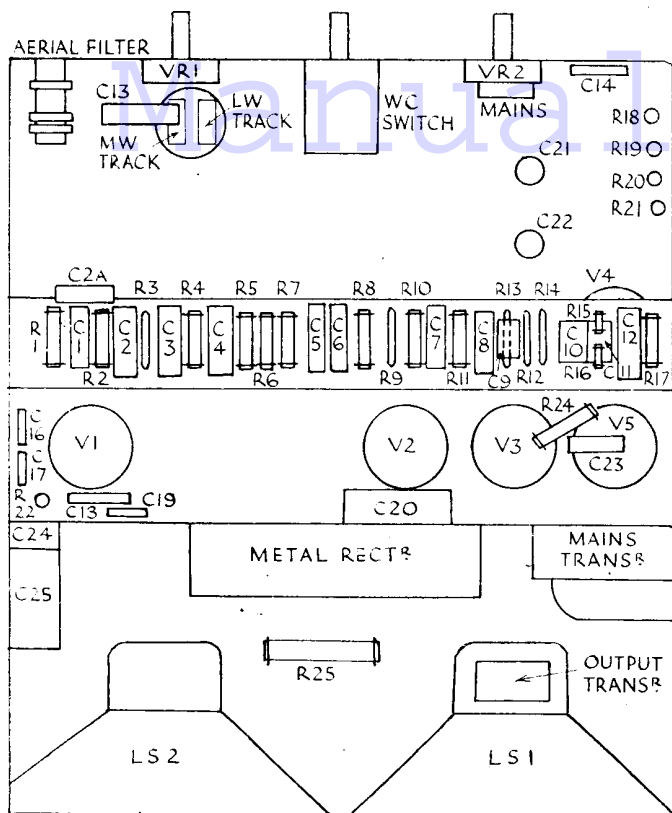

Above is the top plan of the McMichael Twin-speaker Superhet chassis. In early models the medium- and long-wave tracking condensers, were accessible only from underneath (see Special Notes).

The complete assembly can be removed from the cabinet and the underside of the set chassis can be revealed by pivoting it on two rear screws. Left, is the view of the "opened" assembly.

(Continued from previous page.)

the upper chassis on the aerial filter side of the switch) special insulated 12 in. box spanners are obtainable from the makers to allow this adjustment to be made without removing the chassis.

Later models have tracking condensers as shown in the diagrams. These are adjustable from above.

Quick Tests. — Voltages between the following points and chassis:—

Positive plate of rectifier, 370 volts (H.T. unsmoothed).

Left-hand speaker looking from the back and counting tags from the left: (1) and

(2) 250 volts; (3) 248 volts, H.T. smoothed; (4) 240 volts, V5 anode; (5) 370 volts, H.T. unsmoothed.

Left-hand tag on right-hand speaker, 200 volts.

Removing Chassis. — Remove control knobs (grub screw) and wave-change switch lever by undoing central screw.

Remove four holding screws from underneath and slide chassis out.

To reveal the complete chassis, remove two screws from underneath flange in front between the two chassis and remove the two front of the three screws at each side. Pivoting the top chassis on the two rear screws, turn it over till the chassis is

revealed as in the diagram. There are stops to hold it in this position.

General Notes.—The receiver can conveniently be tested and the components examined without removing the chassis but if any alteration or replacement has to be made it is advisable to remove the chassis completely.

Replacing Chassis.—Return the upper chassis to its original position, replace the six sliding screws and slide the chassis carefully into position, taking care that the wave-change switch spindle does not foul the escutcheon.

Replace the four holding screws and the knobs.

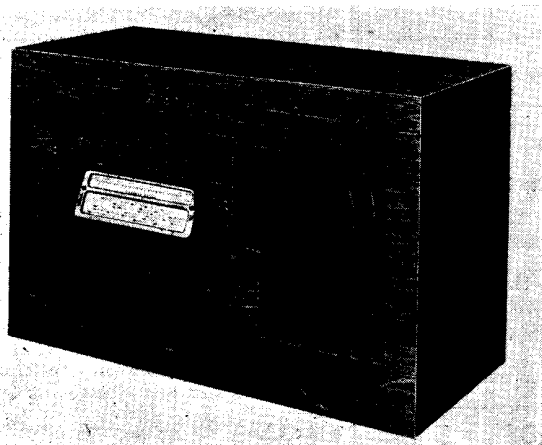

ATLAS TYPE B345 BATTERY SET

The tilting-dial is a distinguishing feature of the Atlas B345 receiver produced by H. Clarke & Co. (Manchester), Ltd.

Circuit.—The H.F. valve, VP2 met. (V1), is preceded by a tuned secondary H.F. transformer with a medium-wave choke in series with the primary to prevent break through on the long waves.

Volume is controlled by a potentiometer across the G.B. battery. Coupling to the next valve is by another tuned secondary transformer.

The second valve, SP2 met. (V2), operates

as a leaky-grid detector with reaction, and is coupled to the output valve by an L.F. choke, damped by the resistance R3, and condenser and grid leak filter.

The output valve, PM22A (V3), is tone compensated by a condenser across the primary of the output transformer.

Special Notes.—Battery voltages are:— H.T.+ (red), 120 v.; H.T.+ (yellow),

80 v.; G.B.+ (grey); G.B.— 4½ (yellow); G.B.— 9 (white).

The volume control resistance acts as a bleeder for the G.B. battery.

Quick Tests.—These are best performed by noting the clicks during valve tests.

Removing Chassis.—Turn dial to horizontal position, remove knobs (grub screw), three screws underneath and undo speaker leads from transformer. Lift the chassis clear of the back stops.

General Notes.—In some models the L.F. choke was omitted, C10 was .05 mfd., and the switch was in the L.T.— lead.

There is no trimmer for the aerial coil on the gang condenser—instead there is a variable type mounted on the front of the chassis.

There are three terminals on the V2 coupling choke, of which the one nearest the end is used only as an anchorage.

The Cord Drive.—To reach the cord inside the dial, remove the two screws at the ends of the chromium-plated frame, taking care not to lose the distance pieces inside.