

For more information remember www.savoy-hifi.co.uk

MARCONIPHONE T21A

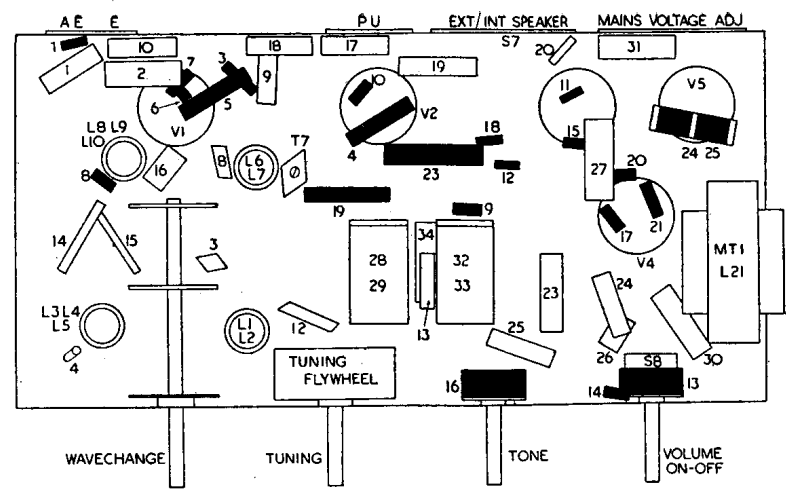

R	1	2	3	4	5	6	7	8	9	10	11	12	13	14	15	16	17	18	19	20	21	22	23	24	25
C	1	2	3	4	5	6	7	8	9	10	11	12	13	14	15	16	17	18	19	20	21	22	23	24	25
L	1	2	3	4	5	6	7	8	9	10	11	12	13	14	15	16	17	18	19	20	21	22	23	24	25

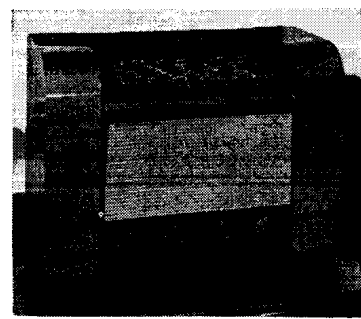
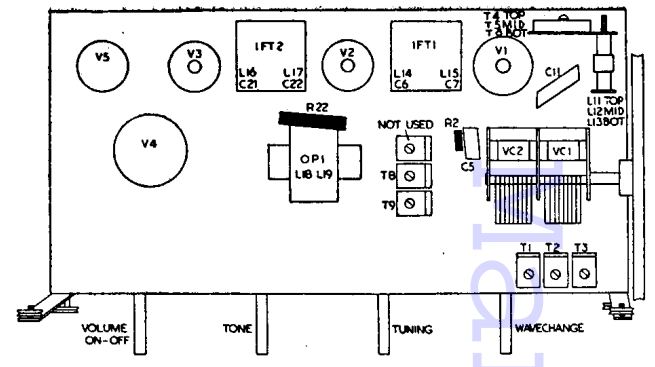

CAPACITORS

C	Capacity	Type
101 Tubular 350V	
2001 Tubular 1,000V	
3	... 5pF Silver Mica	
4	... 30pF Tubular Ceramic	
5	... 100pF Silver Mica	
6	... 100pF Silver Mica	
7	... 100pF Silver Mica	
8	... 100pF Silver Mica	
905 Tubular 350V	
1002 Tubular 350V	
11	... 270pF Silver Mica	
12	... 100pF Silver Mica	
1305 Tubular 350V	
14	... 350pF Silver Mica	
15	... 590pF Silver Mica	
16	... 100pF Silver Mica	
1705 Tubular 350V	
1805 Tubular 350V	
1901 Tubular 1,000V	
20	... 100pF Tubular Ceramic	
21	... 100pF Silver Mica	
22	... 180pF Silver Mica	
2301 Tubular 750V	
2405 Tubular 350V	
2505 Tubular 350V	
26	... 500pF Mica	
2702 Tubular 750V	
28	... 16 Electrolytic 350V	
29005 Tubular 1,000V	
3001 Tubular 1,000V	
3101 Electrolytic 350V	
3201 Tubular 1,000V	
33	... 16 Electrolytic 350V	
3405 Tubular 350V	

RESISTORS

R	Ohms	Watt
1	... 1M...	...
2	... 680K	...
3	... 47K	...
4, 5	... 22K	... WW3
6	... 33K	...
7	... 220...	...
8	... 39K	...
9	... 2.4M	...
10	... 330...	...
11	... 470K	...
12	... 100K	...
13	... 2M	... DPST switch
14	... 4.7K	...
15	... 22M	...
16	... 500K	... Potr.
17	... 47K	...
18	... 22K	...
19	... 1K	...
20	... 2.2K	...
21	... 150...	...
22	... 33
23	... 330...	...
24, 25	... 120	... WW5

INDUCTORS

L	Ohms
125
2	... Very low
3	... 130
4	... 2.5
5	... 24
625
7	... Very low
8	... 1.75
9	... 2.5
10	... 6.5
11	... 2
12	... 2.5
13	... 5
14	... 4.5
15	... 4.5
16	... 4.5
17	... 4.5
18	... 450
195
20	... 4
21	... 175 Total

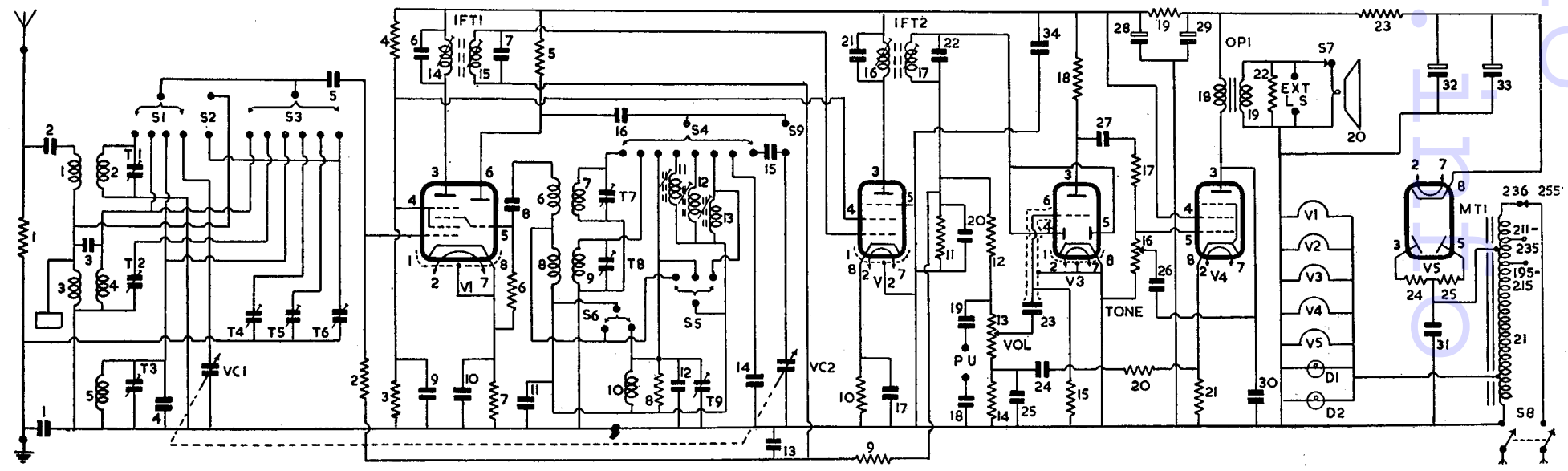
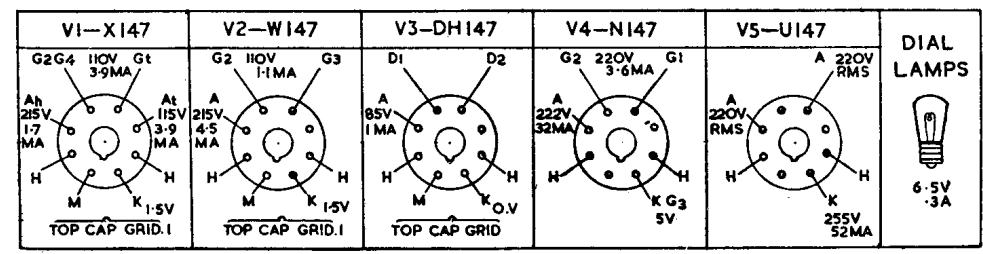

MARCONIPHONE T21A

Continued

Five-valve, three-waveband superhet with three pre-selected stations, fitted with internal plate aerial and sockets for external aerial, earth, high-resistance pickup and low-impedance extension speaker. For 195-255V, 50-100c/s mains. Figured walnut veneered table cabinet. Marketed by Marconiphone Co., Ltd., Hayes, Middlesex.

AERIAL is fed through isolating capacitor C2 to series connected coils L1 (SW), L3 (MW, LW). An internal aerial consists of metal foil attached to inside of cabinet and connected to top of common MW, LW aerial coupling coil L3. Earth socket is isolated from chassis by C1. R1 is a static drain.

Grid coils L2 (SW), L4 (MW), L5 (LW), trimmed by T1, T2, T3, C4 respectively, are switched by S1 to aerial tuning capacitor VC1 and coupled by C5 to triode-hexode frequency-changer V1. S2 which is closed only on SW position connects T6 across the MW, LW aerial coupling coil L3. MW trimmer T2 is brought into circuit across L4 only when receiver is switched to MW band. C3 provides additional capacitive coupling between L3, L4.

On preselected stations trimmers T4, T5, T6 are switched by S3 across L4, L5 and VC1 is switched out by S1. With T4 across L4 as in position 3 the range covered is 200-350 metres. With T5 across L4 as in position 2 the range is 330-550 metres. In position 1 trimmer T6 is switched across L5 and covers 1,250-2,000 metres.

AVC decoupled by R9, C13 is fed through R2 to gl of V1. Cathode bias is provided by R7 decoupled by C10. Screen voltage is obtained from potential divider R3, R4 and decoupled by C9. Primary L14, C6 of IFT1 is in the hexode anode circuit.

Oscillator is connected in a shunt fed tuned anode circuit. The anode coils L7 (SW), L9 (MW), L10 (LW), trimmed by T7, T8, T9, C12 respectively, are switched by S4 through C15 to tuning capacitor VC2, and coupled by C16 to oscillator anode of V1. R5 is oscillator anode load. C15 which is connected in series with VC2 on MW and LW ranges, is shorted out by S9 on SW range. R8 is damping resistor.

On preset stations L11, L12, L13, which are permeability tuned, are switched by S4 to fixed capacitor C14 and then coupled by C16 through to oscillator anode. C11 functions as a padding capacitor for L10 (LW) and the preset tuned coils.

Grid reaction voltages are inductively developed on L6 (SW), L8 (MW, LW) and capacitively from C11 on the three preset stations, and are coupled by C8 to oscillator grid. Automatic bias for oscillator grid is developed by C8, R6. S5 shorts out L8 on SW range and L10 on SW and MW ranges and in addition shorts out L13 in all positions of wavechange switch except position 1. S6 short circuits L10 on all the preset stations and L13 on preset positions 1 and 2.

IF amplifier operates at 465kc/s. Secondary L15, C7 of IFT1 feeds signal and AVC voltages decoupled by R9, C13 to gl of IF amplifier V2. Screen voltage is obtained from potential divider R3, R4 and decoupled by C9. Primary L16, C21 of IFT2 is in the anode circuit.

Signal rectifier—Secondary L17, C22 of IFT2 feeds signal to the strapped diodes of V3. R11 is the load and C20 a filter.

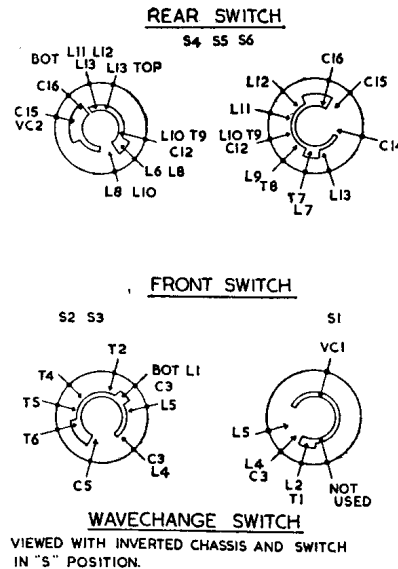

AF amplifier—Signal across R11 is fed through R12 to volume control R13 and through C23 to grid of V3. Bias for grid is developed by C23, R15.

AVC is obtained by feeding the DC component of the rectified signal across R11, through decoupling network R9, C13 to grids of V1 and V2.

Pickup sockets, isolated from chassis by C18, C19, are fitted for connection of any high-resistance pickup. Pickup signal is fed to VC R13 and C23 to V3 grid. Pickup must be unplugged when receiver is used for radio.

Output stage—C27 feeds signal at anode of V3 through R17 to grid of pentode output valve V4. Cathode bias is provided by R21. Screen voltage is obtained from HT line to V1 to V3, decoupling being given by C28.

Primary L18 of output matching transformer OP1 is in the anode circuit, the HT for which is obtained from junction of R19, R23 and decoupled by C29. Secondary L19, provided with a permanent shunt resistor R22, feeds audio signal to a 6 $\frac{1}{2}$ in. PM speaker L20. Sockets are fitted to L19 for connection of a low-impedance (5 ohms) extension speaker. S7 which is a wander plug/socket connection for the internal speaker, enables this speaker to be silenced when an extension speaker is used.

Tone control—C30 gives a fixed amount of top cut, whilst C26 by feeding back the higher frequencies through adjustable potentiometer in the grid circuit of V4 provides variable top cut. In addition, negative feedback from cathode of V4 is fed by R20, C24, R14 through volume control R13 and C23, to grid of triode AF amplifier section of V3.

HT is provided by an indirectly heated half-wave rectifier V5. Anode voltages come from a tapping on the mains auto-transformer MT1, through limiter resistors R24, R25. Resistance-capacity smoothing is given by R23, C32, C33, C29. Additional voltage dropping and smoothing for HT to V1 to V3 and screen of V4 is given by

R19, C28. C31 is to eliminate modulation hum and C34 is an RF bypass. C32, C33 which are strapped together to form a 32mF reservoir smoothing capacitor, should have a ripple current rating of 125mA.

Heaters of V1 to V5 and dial lights are connected in parallel and obtain their current from a 6.3V tapping on the mains auto-transformer MT1. The auto-transformer winding L21 is tapping for inputs of 195-215, 216-235, 236-255V 50-100c/s.

S8, ganged to the volume control, is the ON/OFF switch.

Modifications—The circuit shown overleaf is that of models recently released. Earlier models may differ slightly as follows:—

(1) Earthy side of trimmers T4, T5, T6 connected down to chassis.

(2) Live pickup socket coupled through C19 to top of R11, R12.

Chassis removal—Remove the four push-on control knobs and rear panel of cabinet.

Slip drive cord from under dial pointer clamp. Remove dial light holders from their brackets on dial assembly on top of cabinet. Unsolder L5 leads from the LS terminals. Remove the four chassis bolts on underside of cabinet.

TRIMMING INSTRUCTIONS

Apply signal as stated below	Tune receiver to	Trim in order stated for maximum output
(1) 465 kc/s to gl of V1 via .01mF	—	Core L17, L16, L15, L14
(2) 18 mc/s to AE socket via dummy aerial	18 mc/s calibration	T7, T1
(3) 6 mc/s, as above ...	6 mc/s	Check for sensitivity
(4) 1.3 mc/s, as above ...	1.3 mc/s	T8, T2
(5) 600 kc/s, as above ...	600 kc/s	Check for sensitivity
(6) 300 kc/s, as above ...	300 kc/s	T9, T3
(7) 160 kc/s, as above ...	160 kc/s	Check for sensitivity

PRE-SET STATIONS

(8) 240 kc/s—150 kc/s, as above	Switch position 1	Core L13, T6
(9) 909 kc/s—545 kc/s, as above	Switch position 2	Core L12, T5
(10) 1.5 mc/s—857 kc/s, as above	Switch position 3	Core L11, T4

NOTE—When receiver leaves factory it is adjusted to receive on pre-set station (1) Light Programme on 1,500M, (2) London Regional on 330M, (3) Light Programme on 247M.

MALDEN-BROWN HI-FI AMPLIFIER

DESIGNED for high fidelity reproduction the needs of many quality enthusiasts. It forms the main unit of the Cantabile radiogram marketed by the same firm.

The amplifier consists of a triode input stage which is DC coupled to a triode phase splitter. Outputs from anode and cathode of this valve are resistance-capacity coupled to a pair of triode push-pull driver valves which, in turn, are resistance-capacity coupled to the tetrode push-pull output valves.

The amplifier is designed for high-impedance inputs such as radio feeder units or pickup pre-amplifiers. Output valves are matched for 15 ohms impedance speaker but the multi-ratio output transformer can be connected for other impedances.

Negative feedback from the secondary of the output transformer is fed back to cathode circuit of input valve. No tone control circuits are incorporated and no method of volume control is provided. Normally these are best incorporated in pre-amplifier or feeder unit circuits.

The power unit consists of a full-wave directly heated rectifier, together with associated smoothing chokes and condensers, and a mains input transformer. HT and LT supplies are available for subsidiary equipment.

Amplifier and power unit are built on separate chassis which are bolted together. The assembly is mounted on anti-vibration feet. Construction is sound and is sensibly arranged for easy access to all components. Mains and output transformers are of massive construction and all smoothing and HT coupling capacitors are of the paper type.

We tested the amplifier on a 12 in. PM Speaker using an audio oscillator and standard frequency recordings reproduced by moving-coil pickup. Frequency response appeared to be substantially level between 20c/s and 20kc/s and transient response was excellent. We were impressed by the performance of the amplifier especially at full output of 15W. Hum level is exceedingly low.

It is made by Malden-Brown (Electronics), Ltd., 14, Arlington Street, Piccadilly, London, SW.

FAULTY VOLUME CONTROL.

AN early type GEC receiver gave good loud results but had a rather poor tone. All valve voltages were normal, and all valves up to standard, but the tone resembled that produced by an over-biased AF or output valve.

As the volume control was slightly noisy in action it was dismantled, cleaned and re-assembled. On re-fitting, the set had lost its poor tone.

Investigation revealed that this VC was in the grid circuit of the output pentode, and it can only be assumed that the contact resistance of the control was such as to bring the total grid circuit resistance above the value advised by the valve manufacturer.—G. R. Wilding, Liverpool.

Engineers possessing extensive files of our service charts will find it useful to have a copy of a complete index covering sheets issued between January 1934 and June 1949. Available from the editorial office, it costs 2s. 6d. post free.

For more information remember www.savoy-hifi.co.uk