

MARCONIPHONE 560 AC HMV 521, 522 AC

Four valve, plus rectifier, two wave-band TRF. The 521 is a radiogram, the 522 an autoradiogram, and the 560 a console. For operation on AC mains 100 to 250v, 50/60 cycles. Released in 1931 by the Gramophone and Marconiphone Companies, Hayes, Middlesex.

Circuit.—The aerial is fed via a wire-wound type of tubular condenser to the grid coils L1 (MW) and L2 (LW) of the first HF stage. In earlier models the medium wave coil was not tapped, the connection from C1 being direct to the grid of the screen-grid valve V1. This valve is HF choke-capacity coupled by L7 and C2 to a similar pair of tuning coils L3 and L4, which form the grid circuit of the second screen-grid HF amplifier valve V2.

The screen grid of V1 is decoupled by R1 and C4, while that of V2 is decoupled by R4 and C7. The resistances are wire wound on the tubular condensers.

The HT feed to the screens is common through R6 and R7, decoupled by C8, with R8 in parallel with R7. The efficiency of the two stages is controlled by VR1, which is the radio section of the dual volume control. At minimum volume the potential of the screen grids is brought down to zero.

The cathodes of V1 and V2 have a common biasing resistance R5, which is decoupled by C6. The anodes of V1 and V2 are fed from the junction of a potential divider comprising R2 and R3 with C3 as the decoupling capacity.

V2 is coupled to the tuned grid coils L5 and L6 of the detector valve V3 by the HF choke L8 and condenser C5, with R9 and C9 as the grid leak and condenser.

On radio the grid is at the same DC potential as the cathode, both being slightly above chassis potential by reason of the cathode resistance R10 which is decoupled by C10.

On gram the grid of V3 is connected to the slider of the gramophone section VR2 of the dual volume control which has a limiting resistance R11 in series with it. As the pickup and one side of the volume control is returned to chassis the grid of V3 is biased by R10 to operate as an LF amplifier stage on gram. The anode circuit of V3 comprises the HF choke L9 with its anode

by-pass condenser C11, the coupling resistance R13, and the decoupling resistance and condenser R12 and C12.

C14 couples the LF signal from R13 to the primary L10 of the intervalve transformer, the secondary of which feeds the grid of the pentode output valve V4. The heater circuit of this valve has a centre-tapped resistance R15 across it, and is connected from the centre tap to earth via the biasing resistance R16 which is decoupled by C15.

The primary of the output transformer in the anode circuit of V4 has a tone correction network R17 and C19 across it, while the secondary L13 is provided with a precautionary load R18 to prevent damage to the pentode valve and

output transformer should the receiver be operated without a loudspeaker being connected to the loudspeaker sockets.

A PM loudspeaker is employed having a speech coil DC resistance of 15 ohms. An extra loudspeaker should have a similar resistance speech coil.

The HT supply circuit comprises a full-wave rectifier V5, the output of which is smoothed by the choke L1 which is tuned by C20. C17 is the reservoir condenser, C16 the smoothing capacity.

A mains aerial device comprises a lead and plug which may be inserted into the aerial socket. The other end of the lead is taken to C18, which is in turn connected to one side of the mains supply. The latter is fused in both leads by a 2-amp glass tubular fuse in one lead and a .25-amp cartridge type microamp fuse in the other lead.

VALVE READINGS

With volume control at maximum.

V	Type	Electrode	Volts	Ma
1	MS4	Anode	180	2.5
		Screen	60	.8
		Cathode	1.75	—
2	MS4	Anode	180	3.0
		Screen	80	1.0
		Cathode	1.6	—
3	MHL4	Anode	95	2.8
		Cathode	.5	—
		Grid B	4.2	—
4	PT625	Anode	240	17
		Screen	210	—
		Grid B	4.2	—
5	U10	Anodes	—	17
		(each)	—	17

Pilot Lamp, 6 v, .3 amp., MES.

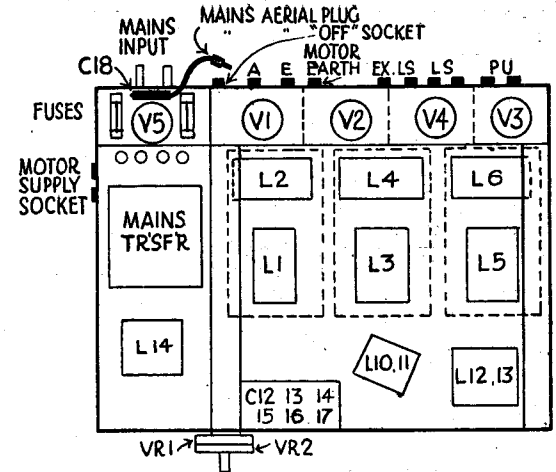

GANGING

Ganging is carried out as is usual with simple TRF circuits by injecting a signal or tuning in a transmission of about 210m and adjusting the trimmers on the three sections of the ganged variable condenser for maximum output. The order of trimming is T1, T2 and T3.

Continued end column, opposite page

RESISTANCES

R	Ohms	R	Ohms
1	600	10	1,200
2	10,000	11	10,000
3	100,000	12	10,000
4	600	13	50,000
5	240	14	10,000
6	10,000	15	20+20
7	100,000	16	1,030
8	100,000	17	25,000
9	1 meg	18	50

CONDENSERS

C	Mfds	C	Mfds
1	.00004	11	.002
2	.001	12	1
3	.001	13	1
4	.1	14	.5
5	.001	15	1
6	.1	16	4
7	.1	17	4
8	1	18	.001
9	.0001	19	.01
10	.1	20	.09

WINDINGS

L	Ohms	L	Ohms
1	2.25	11	10,000
2	12.75	12	1,000
3	2.25	13	1
4	12.75	14	750
5	2.25	15	470
6	12.75	16	580
7	85	17	.1
8	85	18	.1
9	85	19	.5
10	1,000	20	58 (total)
		Speech coil	15

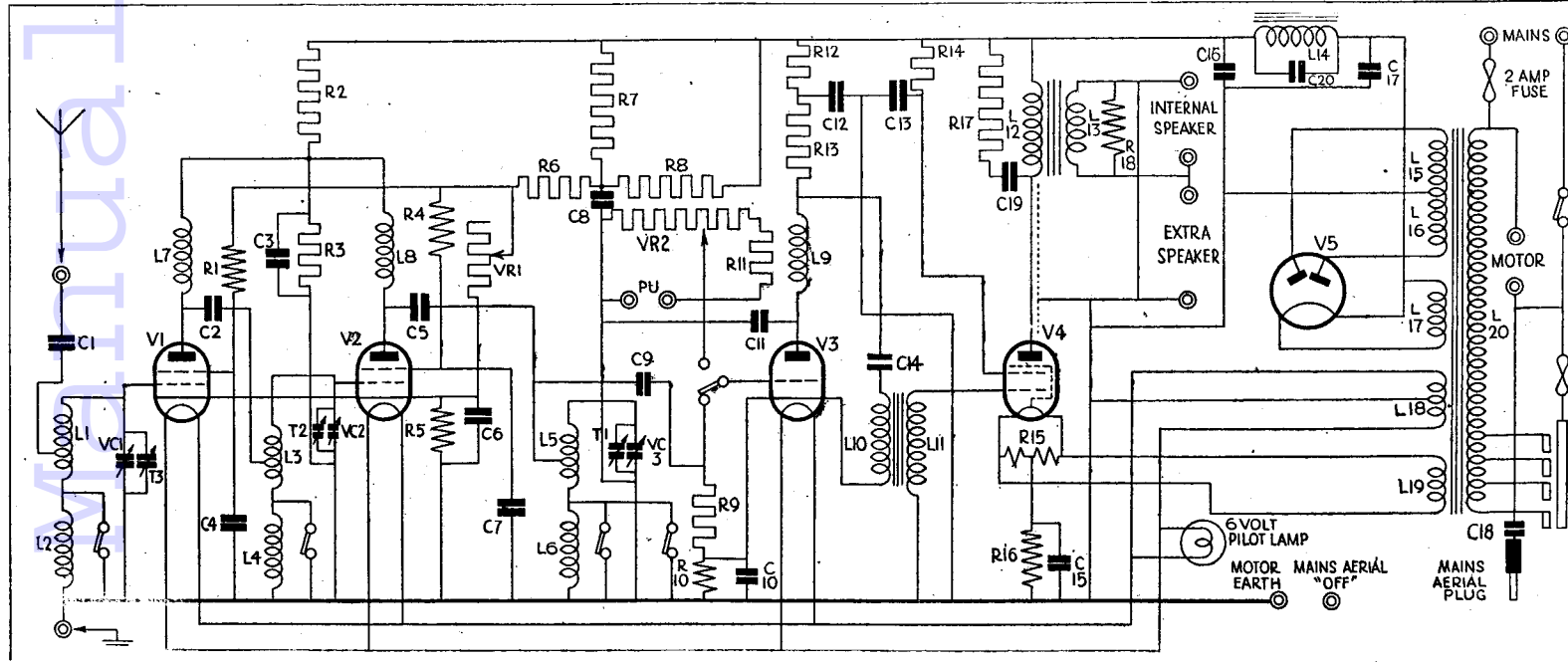

MARCONIPHONE

560 DC

HMV 521, 522 DC

Four-valve TRF chassis. 521 is a radiogram, 522 an autoradiogram and 560 a console. Made for DC mains 190 to 250v by the Gramophone and Marconiphone Companies, Hayes, Middlesex.

Circuit.—The radio characteristics of these models are similar to the AC versions, described on the opposite page. The pickup is isolated by condensers C9 and C10, and, of course, all the heaters of the valves are in series with the voltage dropping resistance R15. This resistance is made up in mat formation and is mounted on the floor of the cabinet. It is connected to the chassis by a cable terminating in a four-pin valve-adaptor plug.

The loudspeaker is of the energised type and has a low resistance field winding of approximately 9 ohms; the required flux is obtained due to the heavy current which flows through the winding, as it is in the unusual position of being in

series with the heater and HT circuits. It will be seen from the circuit diagram that two positions are shown for the field coil, one in the positive mains lead and the other in the negative lead. This arrangement allows the field winding to be inserted in either of these two leads in order to find the position which gives minimum hum.

The leads of the loudspeaker field terminate in a clamp which holds two 5-amp plugs. The two leads go to one plug, while the other plug has its terminals shorted. The clamp is inserted into a pair of 5-amp sockets in the front edge of the chassis, and it is only necessary to withdraw the assembly, turn it over and re-insert it into the sockets to change the field from one mains lead into the other. The field winding leads are red, while the speech coil leads are pink, and are connected to the pink loudspeaker sockets on the chassis.

On all DC models a special type of knob is used which prevents the fingers

VALVE READINGS

Taken on 225 v mains.

V	Type	Electrode	Volts	Ma
1	MS4	Anode	210	2.5
		Screen	60	.7
2	MS4	Anode	210	2.5
		Screen	60	.7
3	MHL4	Anode	90	3.0
4	PT625	Anode	200	19.0
		Screen	180	—

Pilot lamp, 6 v, .3 amp., MES.

of the operator from coming into contact with the spindle via the grub screw. This is effected by an outer sleeve which is kept in place by a grub screw. When this screw is withdrawn, the outer sleeve of the knob may be rotated until a second grub screw is exposed. When this is slacked off the knob may be removed from its spindle.

In the case of the model 522 DC it is important to make sure that the piece of waxed card is reinserted between the top of the radio chassis and the bottom of the auto-mechanism before the mains is

switched on after the instrument has been re-assembled. This is because the chassis is at mains potential while the auto-mechanism is earthed. Due to the small clearance between the screening of the pickup lead and other connections a short will occur unless the card is properly in position.

Before the chassis can be withdrawn from the model 522 the metal motor-board must be removed, and difficulty will be experienced in doing this unless the following procedure is adopted.

After removing the screws round the motor-board, the knobs, and the escutcheon at the base of the PU arm,

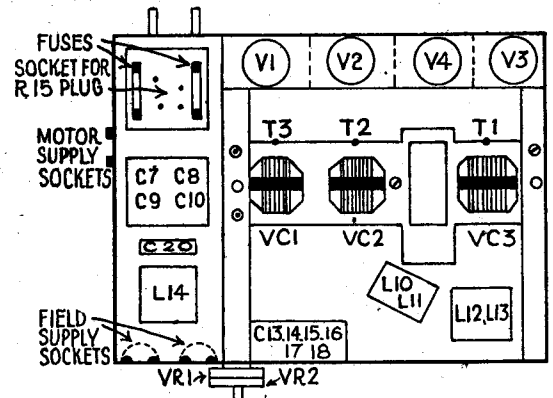

CONDENSERS

C	Mfds	C	Mfds
1	.000,025	12	.1
2	.001	13	1
3	.001	14	1
4	.1	15	1
5	.1	16	.5
6	.1	17	.4
7	.1	18	.4
8	.2	19	.002
9	.5	20	.15
10	.5	21	.01
11	.0001		

WINDINGS

L	Ohms	L	Ohms
1	2.5	10	1,000
2	12.5	11	10,000
3	2.5	12	1,000
4	12.5	13	1
5	2.5	14	800
6	12.5		
7	100	Field	9
8	100	Speech Coil	12
9	100	PU	5,000

RESISTANCES

R	Ohms	R	Ohms
1	600	11	50,000
2	600	12	10,000
3	150	13	25,000
4	10,000	14	50
5	50,000	15	230 (total)
6	50,000	16	5.7
7	50,000	17	8
8	1 meg	18	2
9	2,000	VR1	50,000
10	10,000	VR2	10,000

set the 10- to 12-inch selector control at the left of the turntable to a midway position so that the record supporting assemblies are quite vertical.

Next, engage the motor with the mechanism, by pressing the button in the front of the cabinet and rotate the turntable by hand until the edges of the two jaws of each record support are exactly lined up. The turntable may then be removed, the PU arm raised vertically, and the motor-board lifted off.

GANGING

The circuits are ganged in exactly the same way as the AC models.

Continued from opposite page

Modification to replace PT625.

The following notes will enable the output circuit to be modified so that an MPT4 or MKT4 valve may be used if a PT625 is unavailable.

Disconnect the heater wiring of the PT625 valve holder from terminals 14 and 16 on the mains transformer and connect these two wires to terminals 11 and 13 of the mains transformer. This puts the heater of the output valve stage in parallel with all the other heaters.

Disconnect the screen feed from the centre pin of the PT625 holder, and bring this up through a convenient hole in the chassis and fit it with a spade terminal so that it may be connected to the side pin of the MPT4.

Disconnect from the circuit entirely R15 and its connections. This leaves R16 isolated.

Connect the centre pin of the valve-holder which will now be the cathode connection for the MPT4 to R16, after the latter has been adjusted to a resistance of approximately 250 ohms.

It will be noted that R16 comprises sectional windings, and by means of an ohmmeter it will be found that one of these windings is approximately the desired resistance. This section is the one to use as a bias resistance for the MPT4 with C15 connected across it as a decoupling condenser.

