

MARCONIPHONE MODELS 537 AND 534

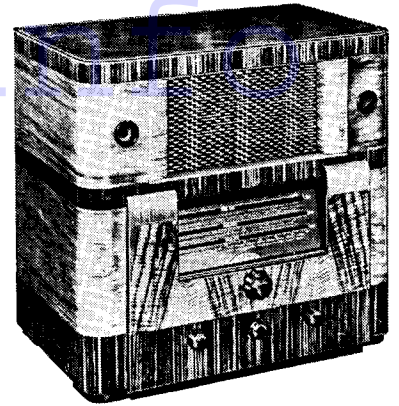

The 537 is a six valve, plus rectifier, all-wave superhet. The slightly earlier 534 is similar but for the cabinet.

CIRCUIT.—The aerial circuit is so arranged that a doublet aerial may be employed if desired when working on short waves. It may be noted also that even if a short-wave doublet aerial is used, the aerial operates as a "T" type on the long and medium waves without any alterations being made.

The aerial is tuned H.F. transformer coupled to the grid of V1, a variable-mu H.F. pentode, working as an H.F. amplifier. The anode circuit includes a set of tuned coils and is capacitively coupled to the grid of V2, the frequency changer. An inductance in the cathode circuit of V2 operates so as to prevent "oscillator drift" when working on the short waves.

The output of V2, consisting of signals converted to a frequency of 465 kc., passes through an I.F. transformer to the I.F. amplifying stage V3, another variable-mu H.F. pentode, and thence to the diode valve V4.

V4 is a double diode with the diodes strapped together. The rectified signal appears across the diode load resistance R9, the D.C. voltage being fed to V5, a triode amplifier. The D.C. voltage across R9 is also utilised in providing A.V.C. and for varying the grid voltage applied to the grid of the tuning indicator.

The output of V5, the L.F. amplifier, is resistance-capacity coupled to the final stage V6, an output pentode, in such a manner that by the operation of switch contacts in the anode circuit of V6 and the L.F. coupling to the same valve, variations in the tone of the receiver can be obtained.

Mains equipment consists of a mains

transformer with the usual voltage adjusting arrangements, a full-wave rectifying valve, V7, smoothing choke (speaker field) and smoothing condensers.

Chassis Removal.—First remove the five control knobs from the front of the cabinet. Of the two controlling the tuning, the smaller knob is fixed by a grub screw while the other is removed with a slight pull. The other three knobs are of the grub-screw fixing type, and care should be taken to avoid misplacing the screws, as these are not screwed into the knobs but screw into the split shafts.

VALVE READINGS

No signal. Volume maximum 200 volt A.C. mains.

V.	Type.	Electrode.	Volts.	Ma.
1	All Marconi. W42 (7) ...	Anode ...	258	Inaccessible.
		Screen ...	20	3
2	X42 (7) ...	Anode ...	278	2
		Osc.anode	145	Inaccessible.
3	W42 (7) ...	Screen ...	68	3
		Anode ...	278	9
4	D41 met. (5) ...	Screen ...	102	22
		Diode ...	—	—
5	H42 (7) ...	Anode ...	135	1
6	N42 (7) ...	Anode ...	260	27
		Screen ...	260	4.5
7	U14 (4) ...	Filament	395	—

Now remove the back of the cabinet by removing the four fixing screws and washers. Pull the valveholder (which is connected to a cable coming from the chassis) from the base of the visual tuning indicator. Now remove the mains on/off switch and unseat the speaker cable.

Turn the set on its side with the mains transformer nearest the bench, and remove the four fixing bolts and washers on the base of the cabinet. The chassis can then

QUICK TESTS

Quick tests are obtainable on this receiver between the speaker transformer and chassis. Volts measured should be:—
 Red lead—395v., unsmoothed H.T.
 Red lead with black—278v., smoothed H.T.
 Red lead with yellow—265v., smoothed H.T.

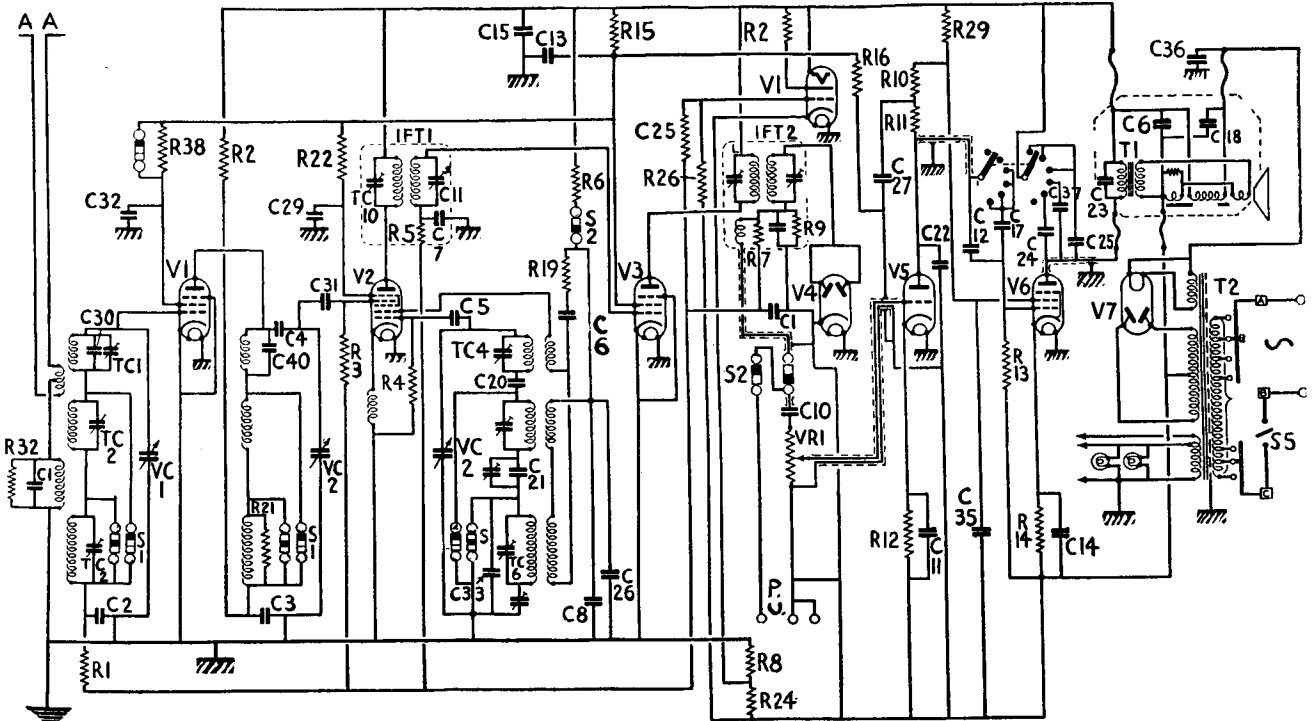

The black section between switch contacts indicates when the contacts are closed. Top to bottom the sections indicate switch positions in the following order: short, medium, long waves, gramophone.

FOR more information remember

be removed from the cabinet to the extent of the speaker cable.

The speaker can be removed by undoing the two fixing screws and washers on the aluminium support bar. If the speaker be removed and it is desired to operate the set out of the cabinet, it is necessary to place the electrolytic condensers in a vertical position (as in cabinet), and care should be taken to ensure that all four leads are connected to the speaker panel before the set is switched on.

Special Notes.—There are three dial lights. Two are mounted one each side of the wavelength dial and are fixed in screw-in holders clamped to the wavelength-dial assembly. The remaining light is fixed in a screw-in holder and clamped to the tuning drive so as to provide a diamond shaped indicator of wavelength position. The dial lights are rated at 4 volts .5 amp. and are fixed in their respective holders with what appears to be beeswax to prevent the bulbs working loose in their sockets.

A pair of sockets, insulated by rubber grommets, on a metal bracket secured to the cabinet enable an external speaker to be used if required. This should be of the permanent-magnet moving-coil type with a resistance of 4 ohms.

A pair of sockets on the rear of the chassis enables a pick-up to be connected. The tuning indicator is a 6E5 visual tuner valve.

R7, R9 and C9 are in the second I.F. transformer can; R19, C6 and C20 are inside the oscillator coil; R5 and C7 are in the first I.F. transformer can. The anode coil can contains R21 and C40. The aerial coil contains R39, C1 and C30. R23 is across the tuning indicator valveholder, and condensers 16 and 18 are mounted on the speaker panel, with C23 across the primary of the speaker transformer.

When the set is operating as a gramophone amplifier the H.T. voltage to the oscillator anode is cut off.

Alignment Notes

I.F. Circuits.—Set the tone control to maximum bass and minimum top volume control to maximum waveband switch to long wave position and fully engage the vanes of the gang condenser. See that the radio-gram switch is in the radio position.

Connect a service oscillator between the top (Continued on page 19.)

Marconi 537 on Test

MODEL 537.—Standard model for A.C. mains operation, 95 to 260 volts, 50-100 cycles. Price 16 gns.

DESCRIPTION.—Three waveband, seven valve, including rectifier, table model superhet.

FEATURES.—Large full-vision scale, with illuminated pointers operated by wave switch. Provision for tone, tuning, volume, and wave selection with separate mains switch. Provision for connection of doublet aerial. Sockets for pick-up and external speaker.

LOADING.—95 watts.

Sensitivity and Selectivity

SHORT WAVES (16.7-54 metres.)—When tested with an ordinary aerial sensitivity and selectivity up to standard for the valve combination employed. Slow-motion tuning control with vernier dial makes for easy handling. No appreciable drift.

MEDIUM WAVES (195-580 metres.)—Good gain and average selectivity. Local stations spread over some adjacent channels, gain well maintained.

Quiet background.
LONG WAVES (725-1,950 metres.)—High gain, reasonable selectivity, difficulty in receiving Deutschland-sender on an ordinary aerial.

Acoustic Output

Ample output for an ordinary room, with very well balanced tone, crisp, clean attack and good radiation at both ends of the scale. Very little colouration on speech and balance generally pleasing.

Condenser Replacements

Five condenser replacements are obtainable from A. H. Hunt, Ltd., of Garratt Lane, Wandsworth, London, S.W.18. For C14 there is unit 3667, at 2s. 6d.; C11, 3668, 2s. 3d.; C18, 3063, 6s. 6d.; C16, 3056, 7s. 6d. The unit containing C's 13, 26, 35 and 27 is list 3669, 9s. 6d.

CONDENSERS

C.	Purpose.	Mfds.
1	M.W. and L.W. aerial shunt	.00005
2	V1 A.V.C. decoupling	.1
3	V1 anode decoupling	.3
4	Tuning condenser isolator	.1
5	Oscillator grid	.00005
6	Short wave osc. feed network	.00015
7	V3 A.V.C. decoupling	.1
8	Osc. anode decoupling	.1
9	H.F. by-pass	.00035
10	L.F. coupling	.01
11	V5 cathode shunt	.25
12	L.F. coupling	.001
13	V3 screen decoupling	.4
14	V6 cathode shunt	.25
15	H.T. line decoupling	.1
16	H.T. smoothing	.16
17	Tone control	.01
18	H.T. smoothing	.10
19	A.V.C. decoupling	.1
20	Short wave fixed padler	.00285
21	Medium wave fixed padler	.00035
22	V6 anode shunt	.001
23	Pentode compensating	.001
24	Tone control	.005
25	Tone control	.025
26	Osc. anode decoupling	.1
27	V5 anode decoupling	.1
29	V2 screen decoupling	.05
30	V1 short wave coil fixed trimmer	.00005
31	V2 grid coupling	.0001
32	V1 screen decoupling	.1
33	Long wave fixed oscillator trimmer	.000035
35	V6 screen decoupling	.4
36	H.F. by-pass	.0023
37	Tone control	.01
40	V1 short wave fixed anode trimmer	.00005

RESISTANCES

R.	Purpose.	Ohms.
1	V1 A.V.C. decoupling	100,000
2	V1 anode decoupling	10,000
3	V2 grid	500,000
4	V2 osc. grid leak	50,000
5	V3 A.V.C. decoupling	100,000
6	Osc. anode decoupling	23,000
7	A.V.C. decoupling	500,000
8	V1, V2, V3 cathode bias potr. (part)	75
9	Diode load	500,000
10	V5 anode decoupling	10,000
11	V5 anode load	75,000
12	V5 cathode bias	2,300
13	V6 grid leak	500,000
14	V6 cathode bias	500
15	V3 screen decoupling potr. (part)	6,700
16	V3 screen decoupling potr. (part)	6,000
19	S.W. oscillator feed	100
21	L.W. anode shunt	50,000
22	V2 screen decoupling	15,000
23	Tuning indicator feed	1 meg.
24	V1, V2, V3 cathode bias potr. (part)	34
25	Tuning indicator grid decoupling	2.3 meg.
26	Tuning indicator grid bias feed	2.3 meg.
29	V6 screen decoupling	3,500
38	V1 screen decoupling	750,000
39	M.W. and L.W. aerial shunt	350
VR1	Volume control	500,000

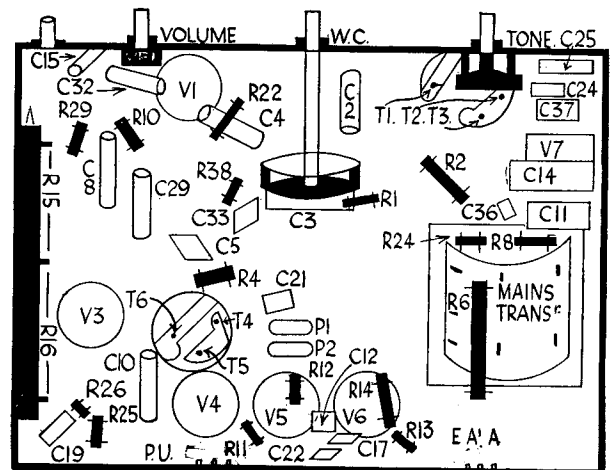
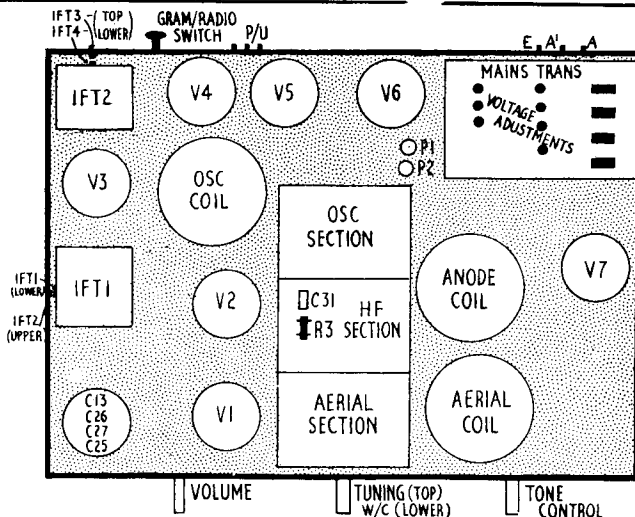

These diagrams enable the components in the 537 to be identified. Some, however, are housed in the coil cans. These are listed under "Special Notes"

For more information remember
www.savoy-hill.co.uk

kc. and adjust the trimmers of the second I.F. transformer for maximum response. Repeat with the first I.F. transformer reducing the input from the oscillator as the circuits come into line to render the A.V.C. inoperative. It may be noted that the trimmers are sealed by paper strips.

Signal Circuits.—Leave the output meter connected as before but connect the oscillator to the aerial and earth terminals of

QUICK TESTS

These are available on this receiver on the speaker transformer. Volts measured between this and the chassis should be:—

- Red lead, 200 volts, smoothed H.T.
- Black lead, 180 volts, smoothed H.T.

VALVE READINGS

No signal. Volume maximum. 200 volts A.C. mains.

V.	Type.	Electrode.	Volts.	Ma.
1	Mazda TH2320 (met. 7)	Anode ...	185	Inaccessible.
		Screen ...	67	
		Osc. anode ...	70	
2	Mullard VP13C (met. 7)	Anode ...	185	9.8
		Screen ...	90	3.6
3	Brimar 10D1(5)	Double diode.	—	—
4	Brimar 7 DC(7)	Anode ...	180	25
		Screen ...	190	5
5	Mullard Ur1c(5)	Filament	200	—

the receiver through a .0002 mfd. fixed condenser or a dummy aerial. Only feed sufficient input from the oscillator to obtain a half-scale reading on the output meter so as to keep the A.V.C. inoperative.

Short Waves.—Tune set and oscillator to 19 metres (15,789 kc.) and adjust S.W. oscillator trimmer and S.W. aerial trimmer for maximum response (in that order).

Medium Waves.—Tune set and oscillator to 220 metres (1367 kc.) and adjust M.W. oscillator trimmer and M.W. aerial trimmer respectively for maximum.

Tune set and oscillator to 500 metres (600 kc.) and adjust M.W. padding condenser for maximum response, simultaneously rocking the gang to ensure optimum results.

Long Waves.—Tune set and oscillator to 1,200 metres (250 kc.) and adjust L.W. oscillator trimmer for maximum.

Tune set and oscillator to 1,875 metres (160 kc.) and adjust the L.W. padding condenser for maximum, simultaneously rocking the gang to ensure optimum results.

Replacement Condensers

Two condensers by A. H. Hunt, Ltd., are available for replacements in this set. They are: unit number 2933, containing C's 23 and 24, price 8s. 6d., and unit number 2918, for C1, price 1s. 9d.

Decca 66 on Test

MODEL 66.—Standard model for A.C. or D.C. mains, 200-250 volts, 50-60 cycles. Price 9½ gns.

DESCRIPTION.—Four valve, plus rectifier and barretter, three-waveband A.C.-D.C. transportable in walnut horizontal-type table cabinet. For use with external aerial.

FEATURES.—Full-vision scale with names and wavelengths. Dual-ratio tuning. Colour wave-band indication. P.U. and E.S. sockets are provided.

LOADING.—95 watts.

Sensitivity and Selectivity

SHORT WAVES (19-49 metres).—Good sensitivity and reasonable selectivity. Easy handling and no appreciable frequency drift.

MEDIUM WAVES (200-550 metres).—Average performance for the valve arrangement. Good programme strength available on all main stations using average size aerial.

LONG WAVES (900-2,000 metres).—All main stations well received.

Acoustic Output

Reproduction is good in view of the size of the receiver. Balance is attractive on both speech and music and colouration is very slight. Adequate volume for average room.

MARCONI 537

(Continued from page 9.)

grid cap of V2 and earth and an output meter across the primary of the speaker transformer.

Tune the service oscillator to 465 kc. and adjust IFT1, IFT2, IFT3 and IFT4, in that order, for maximum response in the output meter. Reduce the input as the circuits come into line to render the A.V.C. inoperative.

Signal Circuits.—First check the setting of the tuning pointer with relation to the gang condenser. With the vanes of the gang condenser fully disengaged, the tuning pointer should be just below 200 metres. If this is not the case, slacken the screws holding the double-ended spring and slide until the correct reading is obtained, then tighten the screws.

Long Waves.—Set the tone and volume controls as for I.F. circuits, but connect the service oscillator leads to the aerial and earth sockets via a .0002 mfd. fixed condenser.

Set the condenser vanes to minimum and then turn to six degrees on the vernier scale. Tune the oscillator to 725 metres (413.8 kc.) and adjust T6 and T3 in that order for maximum.

Set the oscillator to 1,900 metres (157.9 kc.) and tune the set to 1,900 metres. Adjust P1 for maximum response, simultaneously rocking the gang.

Repeat all the above long-wave operations to ensure correctness of trimmer settings.

Medium Waves.—Set the gang condenser to minimum and tune the oscillator to 197 metres (1,522 kc.). Adjust T5 for maximum.

Set the receiver and oscillator to 240 metres (1,247 kc.) and adjust T2.

Tune the set and oscillator to 550 metres (545 kc.) and adjust P2 for maximum, simultaneously rocking the gang condenser.

Switch set back again to the long-wave band and, setting oscillator to 725 metres (413.8 kc.) and receiver to 725 metres position, adjust T6 for maximum.

Switch the set back to medium waves and tune the set and oscillator to 197 metres (1,522 kc.), and finally adjust T5 very carefully.

Short Waves.—Connect the oscillator leads between the top grid cap of V1 and chassis via a 1 mfd. condenser and tune the oscillator and set to 16.8 metres (17,804 kc.). Adjust T4 for maximum, at the same time rocking the gang.

Connect oscillator to the aerial and earth sockets via a 400-ohm resistance. With the oscillator tuned to 16.8 metres, adjust T1 for maximum, whilst rocking the gang condenser.

Repeat the above operations.

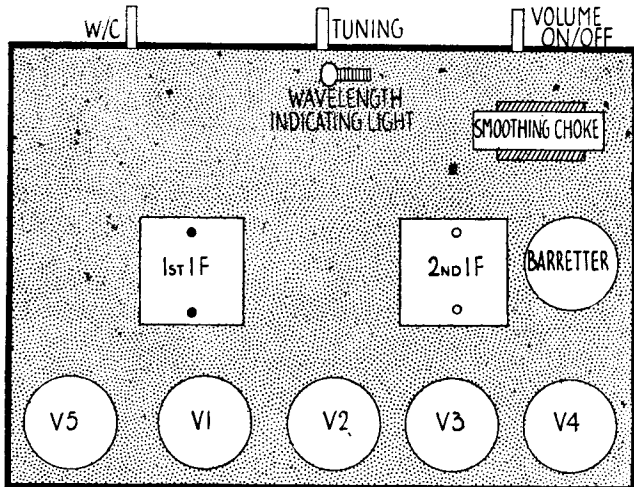

As the top deck chassis diagram on the left shows the Decca 66 is remarkably "clean." The valves are accessible and even the gang is out of sight.

Right are practical details of the layout adopted by Decca for the underside of their chassis for the Model 66. The trimmers are arranged in a logical and accessible manner.

