

HMV 1119

Four-valve, plus rectifier, transportable for 195-255 v 40-60 c/s covering three wavebands and fitted with push-buttons for wave changing and for three MW and two LW pre-set stations. Marketed by EMI Sales and Service Ltd., Hayes, Middlesex.

CIRCUIT consists of a triode-hexode frequency changer V1 feeding into a variable-mu pentode IF amplifier V2. Signal rectification, AVC and a stage of AF amplification are combined in a double-diode triode V3. The output valve is a high-slope power amplifying tetrode V4. This drives an eight-inch mains-energised loudspeaker.

Three of the press buttons control wave changing

(SW, MW and LW) on manual tuning. The other five buttons select predetermined frequencies (two on LW and three on MW). Provision is also made for connection of high-resistance pickup or record player and also a low-impedance external speaker. Both pickup and external speaker are switched.

Aerial circuit. The external aerial or internal plate aerial is coupled by high impedance coils L1(SW), L3(MW), L5(LW) to tuned coils L2(SW), L4(MW) and L6(LW). Capacitor C2 across L5 (LW) coil is for image rejection. Press-button switches S1 to S3 bring into circuit across the tuning coils the manual tuning capacitor VC1 and also couple the circuit through C4 to grid of V1. T7 is MW and T6 is LW trimmer.

Press-button switches S5 to S7 connect the pre-set capacitors T1 to T3 across the inductance L4 for MW pre-selected frequencies. S8, S9 connect T4 and T5 across L6 for LW stations. S4 is closed when any of the switches S5 to S9 is operated.

AVC is applied to grid V1 through R3. Cathode bias is provided by R4 and decoupled by C7. Screen voltage is obtained from bleeder network R1, R2 and is decoupled by C6 and C27. Primary L17 of IFT1 is in the anode circuit of V1.

Oscillator is connected in a tuned grid circuit. Press-button switches S10 to S12 connect the oscillator manual timing capacitor VC2 to the coils L8(SW), L10(MW), L11(LW). C12 is in series with VC2 for MW and LW operation T8(MW) and T9(LW) are trimmers.

Inductive reaction is developed across L7(SW), L9(MW) and capacitive reaction across C9(LW) and is fed back to the oscillator anode circuit-C8 is SW padding capacitor.

Press-button switches S14 to S18 bring into circuit, across fixed capacitor C13, variable inductances

(Continued on page iv)

RESISTORS

R	Ohms			
1	15K 2W	12	2.2K	1W
2	15K 1W	13	680K	1W
3	470K 1/2W	14	680K	1/2W
4	220 1/2W	15	10K	1/2W
5	47K 1/2W	16	150K	1/2W
6	22K 1/2W	17	68K	(Not fitted on Model tested)
7	330 1/2W			
8	150K 1/2W	18	330K	1/2W
9	150K 1/2W	19	22K	1/2W
10	330K 1/2W	20	50K	Potentiometer
11	2 Meg. Potentiometer (With Switch)	21	15	1W
		22	100	1/2W

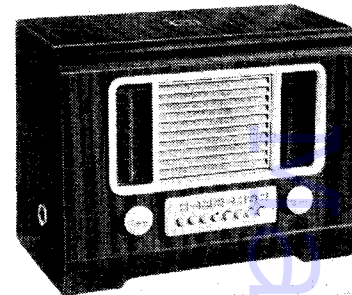

HMV Model 1119 INDUCTORS

L	Ohms			
1	.6	7	...	20
2	...	86
3	very low	9	...	very low
4	...	10	...	1.5
5	5.5	11	...	3
	60	12	...	8.5
		13	...	10.5
		14	...	10.5
		15	...	4.5
		16	...	4.5
		17	...	2
		18
		19	...	5
		20
		21	...	400
		22	...	very low
		23	...	3.5
		24	...	950
		25	...	315
		26	...	very low
		27	...	very low
		28	...	25

CAPACITORS

C	Mfds
1	50pF Silver Mica
2	500pF "
3	2.3pF "
4	100pF "
5	.05 Tubular
6	.05 "
7	.05 "
8	.005 Silver Mica
9	350pF "
10	50pF "
11	75pF "
12	500pF "
13	230pF "
14	.05 Tubular
15	100pF Silver Mica
16	100pF "
17	230pF "
18	.05 Tubular
19	.05 "
20	.05 "
21	.05 "
22	.002 "
23	...
24	200pF Silver Mica
25	...
26	...
27	8 Electrolytic 500v
28	8 " 450v
29	50 " 12v
30	8 " 450v
31	16 " 500v

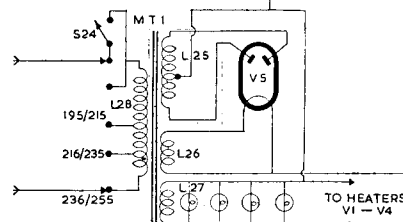
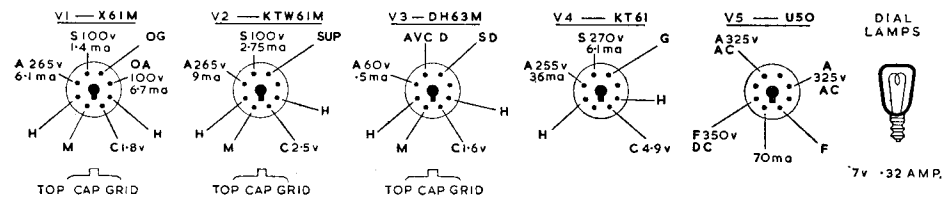
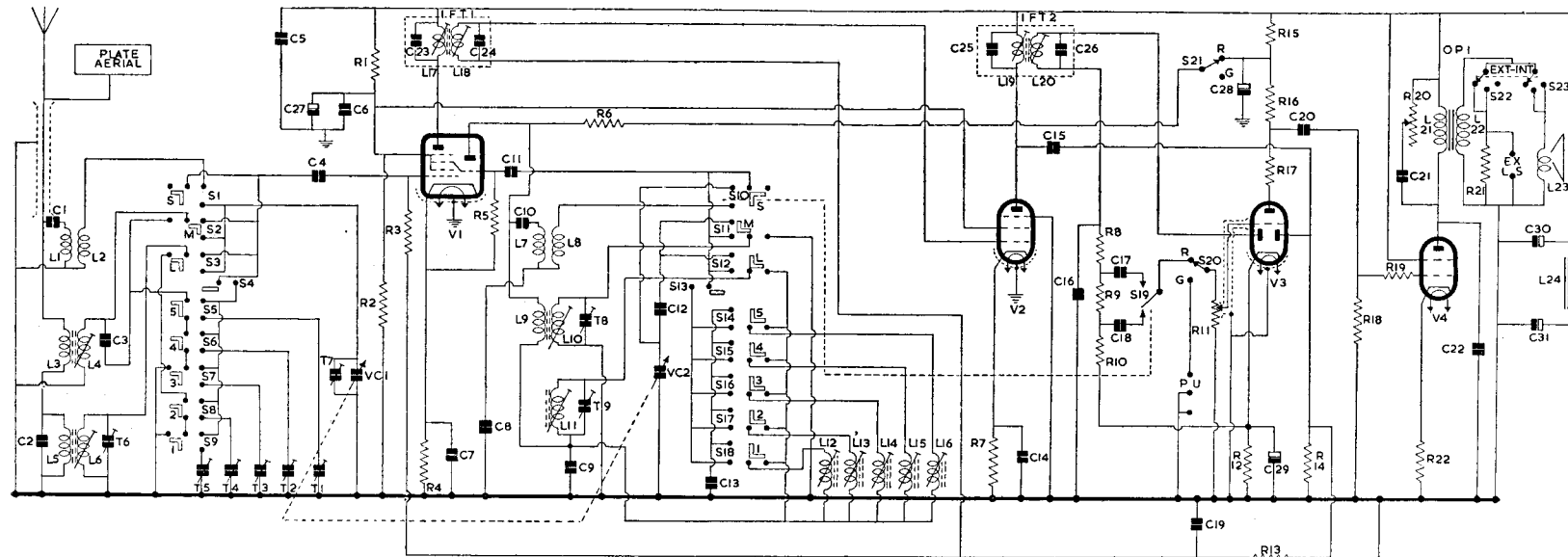

HMV III9—Continued

L16, L15, L14 for selected MW frequencies and L13, L12 for selected LW frequencies. S13 is closed when any of the switches S14 to S18 are operated. On press-button frequencies anode reaction voltages are developed across the capacitor C9.

R6 is oscillator anode load resistor and oscillator HT is obtained through S21, from R15. S21 is ganged to the radio-gram switch S20, and removes the oscillator HT when in the gram position.

IF Amplifier operates at 465 kc/s. Secondary L18 of IFT1 applies the signal to grid V2, a high slope HF pentode. AVC is fed to grid, through secondary L18, from R13. C19 is AVC decoupling capacitor. R7, C14 provide decoupled cathode bias. Screen voltage is obtained from bleeder network R1, R2 as in the case of screen V1. L19, primary of IFT2, is in the anode circuit of V2.

Signal Rectifier. Secondary L20 of IFT2 feeds signal to one diode of V3. R8, R9, R10 form the diode load. On MW and LW C18 feeds the signal through S19, S20 to volume control R11, but on SW the signal is fed through C17 to R11. This pro-

duces a bass cut on the SW frequencies. S19 is ganged to S1 and S10.

PU sockets are fitted between chassis and S20 and when S20 is in the gram position PU is connected across the volume control R11. Rectified signal is tapped off R11 and fed to grid of triode section V3.

AVC. C15 feeds signal from primary of IFT2 to diode anode. R14 is diode load resistor and R13, C19 decouple the AVC line to grids V1 and V2. Delay voltage is provided by cathode bias across R12.

AF Amplifier. Triode grid of V3 is fed from volume control R11. Cathode bias is provided by R12 and decoupled by C29. R16, R17 form the anode load of V3. R15 with capacitor C28 provides decoupling.

Output Stage. C20 feeds signal to grid V4 through stopper resistor R19. R18 is the grid resistor. (Note: on model tested C20 was connected to anode V3 and R16, R17 were replaced by a single resistor of 150K).

Negative feedback is introduced by leaving the cathode bias resistor R22, undecoupled. Primary

(Continued on bottom of page vi)

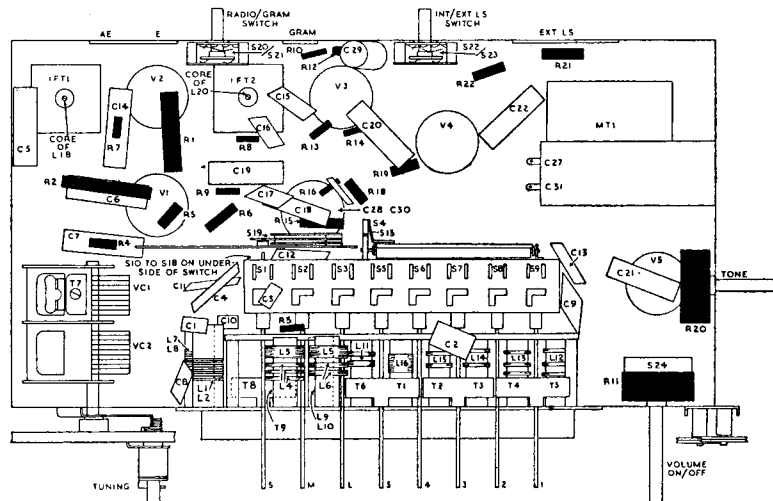
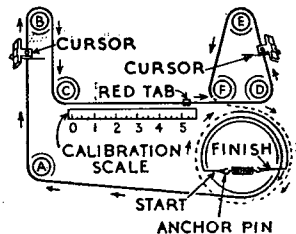
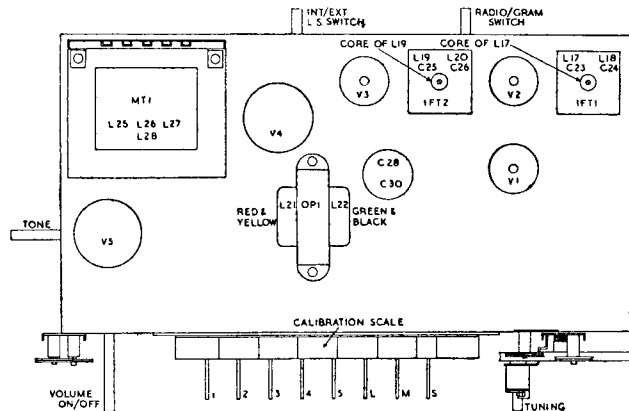

Top left: Top layout of chassis

Above: Cord drive for tuning

Lower left: Bottom layout of chassis

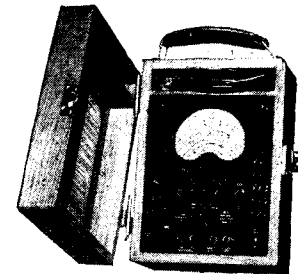

ALL-PURPOSE TESTER

MULTI-RANGE TESTING SET FOR A.C. AND D.C.

Measures: Volts — Amperes — Resistance and Capacity.

- RANGES: 5, 25, 125, 250 and 1,000 volts. 1, 10, 100 and 1,000 Milliamps. 150 to 50,000 ohms and 7.5 Megohms. .02 to 16 Microfarads.
- "Dwarf" Omni-Range Current Transformer giving ranges on A.C. of 10, 25, 50, 125 and 250 amperes. the secondary current being 1 ampere.

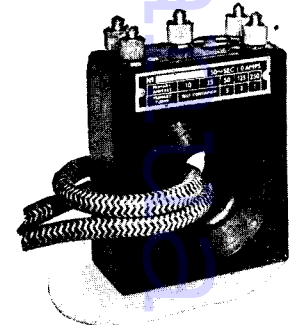

EVERETT EDGCUMBE

Manufacturers of all kinds of indicating and recording electrical instruments. Photometry experts.

Colindale Works, London, N.W.9

WHO SAYS WE ARE UP AGAINST IT

IF AN ELECTRICAL CONTACT WON'T

WORK

IT MUST WANT

A FEW DROPS OF SERVISOL. IT'S UP TO YOU!

SERVISOL LTD. CROWN WORKS BOUNDARY PLACE · LIVERPOOL 7.



Servisol is now Exported to all Countries in the World

BSR AMPLI- GRAM

This drawing identifies components mounted beneath the chassis of the BSR Ampligram. Other details on previous page

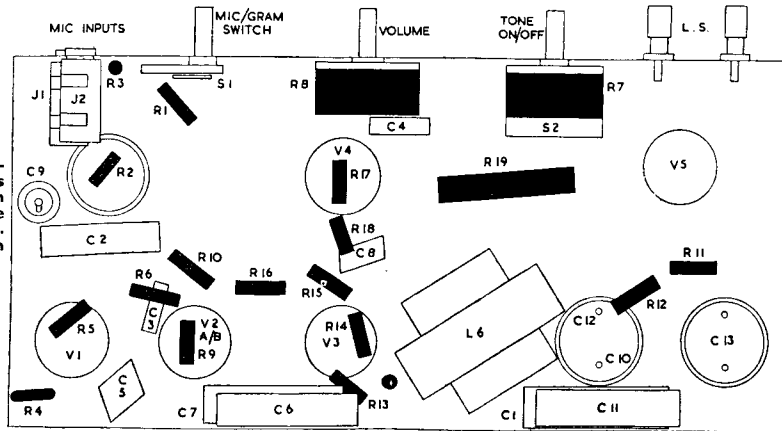

HMV III9—Continued

L21 of OP1, the output matching transformer, is connected in anode circuit of V4. R20 with C21 provides variable top cut. C22 is anode bypass capacitor.

Secondary L22 of OP1 is taken to ganged switches S22 S23 and thence to either L23, the internal speaker, or to R21 and external speaker sockets. S22, S23 allow internal and external speakers to be operated either together or individually. R21 is to prevent load on secondary of OP1 being removed should external speaker be disconnected whilst set is operating in external position.

HT is provided by a directly heated full-wave rectifier V5. L25 supplies its anode voltages and L26 its filament voltage. L24, the speaker field winding, with C30 and C31, provides HT smoothing. C5 is HF decoupler for HT supply.

Heaters of V1 to V4 are supplied from L27 as are the four 7V dial lamps.

Primary L28 of MT1 is tapped for mains input voltages 195/255V, 40/60 c/s. S24, ganged to R11, the volume control, is the on/off switch.

Dismantling. Minor replacements may be carried out by removing the back and the service hatch from underneath the cabinet. For ganging and major replacements the chassis must be removed.

Remove two front knobs (screw fixing) and pull off the tone-control knob at side of cabinet (spring fixing). Remove the card back (four screws) and the four pilot lamps (clip fixing). Unscrew the two cursors from the condenser drive wire. Remove four fixing screws from the underside of the cabinet and withdraw.

The scale and the two cursors are fitted to the cabinet.

Pointer Drive. Obtain wire from EMI Sales and Service. Form $\frac{1}{8}$ in. soldered loop at one end. Pass through hole in drum and place on anchor pin. Run wire as shown in diagram, assemble spring, twist wire and solder. Place chassis in cabinet, assemble cursors to wire, check setting of pointers (see alignment instructions).

TRIMMING INSTRUCTIONS

Before commencing trimming check calibration scale pointer. The trailing edge of "red tab" should coincide with 5 $\frac{1}{2}$ in. mark. If adjustment is necessary slacken the two screws securing scale and adjust scale.

Apply Signal as stated below	Tune Receiver to	Trim in Order stated for Max. Output
1) 465 kc/s to grid V2 via a .05 Capacitor	Press SW button. Vol. at Max. Tone Fully Anti-clockwise. Gang at Max.	Shunt L19 with 33K Resistor. Core L20. Shunt L20 with 33K Resistor. Core L19.
2) 465 kc/s to Grid V1 via a .05 Capacitor.	—	Shunt L17 with 33K Resistor. Core L18. Shunt L18 with 33K Resistor. Core L17.
3) 1427 kc/s to AE Socket via Dummy Aerial and press MW button. ...	Calibration Scale pointer to $\frac{3}{8}$ in.	T8, T7.
4) 588 kc/s as above	4 $\frac{1}{2}$ in.	Core L10, L4 and Repeat (3) and (4)
5) 300 kc/s as above and press LW button ...	1 $\frac{3}{8}$ in.	T9, T6
6) 162 kc/s as above	4 $\frac{3}{8}$ in.	Core L11, L6 and repeat (5) and (6)
7) 6 mc/s as above and Press SW Button.	5 $\frac{1}{2}$ in.	Adjust L8 Loop .. L2 Loop

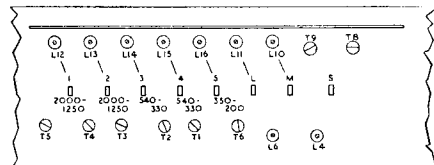

There are two trimmers for each push-button station. Adjust coil core first, then the RF trimmer for required station

PIFCO

METERS at PRICES BELOW
PRESENT DAY COST

Immediate delivery

Panel-mounting moving-coil meter illustrated is in Black Bakelite case, 2 $\frac{1}{4}$ " x 1 $\frac{1}{2}$ ". 0-40 volts.

Also available are :

- Voltmeter 2 $\frac{1}{4}$ " x 1 $\frac{1}{2}$ " 0-20 Volts.
- Voltmeter 2 $\frac{1}{8}$ " x 1 $\frac{1}{2}$ " 0-600 Volts.
- Milliammeter 3" x 1 $\frac{1}{4}$ " 0-50 M.A.
- Milliammeter 1 $\frac{1}{2}$ " x 1 $\frac{3}{16}$ " 0-75 M.A.
- Ammeter 2 $\frac{1}{4}$ " x 1 $\frac{7}{8}$ " 50-0-50 Amp.
- Oil Pressure Gauge 2 $\frac{1}{4}$ " x 2 $\frac{1}{2}$ " 0-160 lbs.

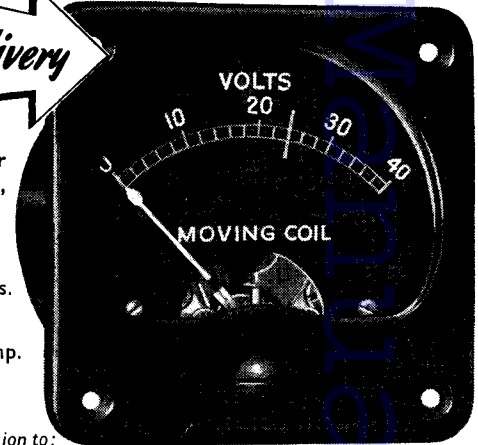

Illustrated folder and trade prices on application to:

PIFCO LTD. · PIFCO HOUSE · WATLING ST. · MANCHESTER, 4

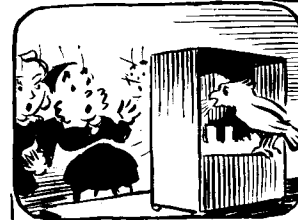

"What's wrong with our wireless to-night?"
"I'm sure we fixed it all right, Yes, it's squeaking and bleating and keeps on repeating."
"Now twerps—go and fetch the FLUXITE."

For all SOLDERING work you need FLUXITE—the paste flux—with which even dirty metals are soldered and "tinned." For the jointing of lead—without solder and the "running" of white metal bearings—without "tinning" the bearing. It is suitable for ALL METALS—excepting Aluminium—and can be used with safety on Electrical and other sensitive apparatus. With FLUXITE, joints can be "wiped" successfully that are impossible by any other method. OF ALL IRONMONGERS, in tins—10d., 1/6 & 3/- Used for over 40 years in Government works and by leading Engineers and Manufacturers. "The FLUXITE GUN" puts Fluxite where you want it by a simple pressure. Price 1/6 or filled 2/6.

FLUXITE

SIMPLIFIES ALL SOLDERING

Write for Leaflets on Case-Hardening Steel and Tempering Tools with FLUXITE, also on "wiped" joints. Price 1d. each. FLUXITE LTD., (Dept. T.E.), Bermondsey St., London, S.E.1.

STURDY FOR REWINDS

For all-round satisfaction, send your rewinds to Sturdy. First-class work, returned in the shortest possible time, and fully guaranteed. For the trade only.

STURDY ELECTRIC CO., LTD.
DIPTON, NEWCASTLE-ON-TYNE
Phone: DIPTON 221. Lists on application.