

FERRANTI

1137B, 1237B

Four-valve, three-waveband, battery superhet with QPP output. Model 1137B has a moulded cabinet and 1237B a wood cabinet. In all other respects the models are identical. Marketed by Ferranti Ltd., Moston, near Hollinwood, Lancs., and Kern House, Kingsway, London, W.C.2.

THE aerial input is switched to short-wave coils L1, L2, and thence to the grid of the heptode frequency changer V1, or to a band-pass filter unit on medium and long wave. L3 and L4 are the MW and LW coupling coils with L5 and L6 the primary windings tuned by VC1 section of the triple-ganged condenser.

Inductive and capacity coupling is employed via C2 and L7, the secondary coils being L8 and L9 tuned by VC2.

The oscillator section of V1 employs tuned grid circuits L10, L12, L14 with oscillator anode reaction coils L11, L13, L15. R2 and C3 are the grid leak and condenser with R3 a regeneration modifier in the grid circuit.

The intermediate frequency signals are transferred from V1 to V2, a pentode, by the IF transformer L16, L17 and a second transformer L18, L19 couples the signal to the signal diode of the double diode triode V3.

The load resistance is R10 filtered by R9, C11 and C12, and the low frequency needed signals are coupled by C13 to the volume control R11 and thence to the triode section of V3.

The automatic volume control diode is fed from L19 via C14, the load resistances being R12, R13. AVC is applied to the grid circuits of V1 and V2.

LF signals are resistance-capacity coupled by R15, C15 to the primary, L20, of the inter-valve driver transformer. A tone control comprising C16 and R14 is connected across L20.

From L21 the signals are fed to the grids of the quiescent push-pull output pentode V4 and the anodes

are connected in the usual way to the primary L22 of the output transformer. L23 is the transformer secondary and L24 the speech coil.

GANGING

IF Circuits.—To line up the IF circuits inject a 125 kc signal to the grid of V1 and chassis. Adjust T1, T2, T3 and T4 for maximum output.

MW Band.—Turn tuning condenser to minimum capacity and adjust pointer to 200 m.

Tune receiver to 228 m (1,315 kc) and inject a 228 m signal.

Screw oscillator trimmer, T5, to maximum (anti-

Continued overleaf.

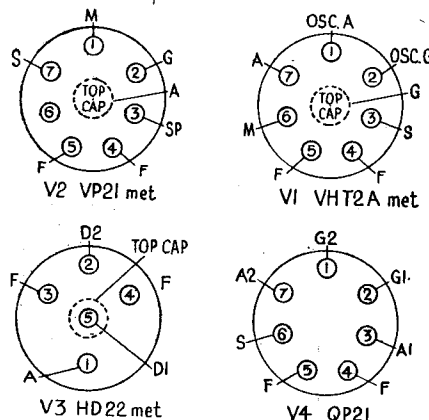

VALVE READINGS

With new battery. Maximum volume control, no signal

V	Type	Electrode	Volts	Ma
1	VHT2A Met. Ferranti	Anode	135	1.4
		Osc. anode	108	.7
		Screen	54	1.4
2	VP21 Met. Osram	Anode	136	2
		Screen	54	.45
3	HD22 Met. Osram	Anode	64	1.55
		Screen	64	.6
4	QP21 Osram	Anodes	138	.9
		Screens		.6

Pilot lamps, 2.5 v., .2 amp M.E.S.
 * Valve code letter V 132 v. tapping.
 W 138 v. "
 X 144 v. "

When HT + tapping is 150 v.

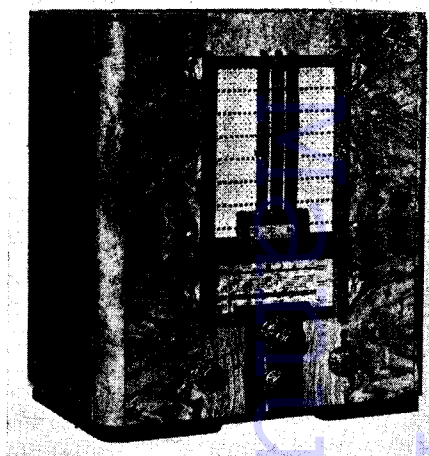
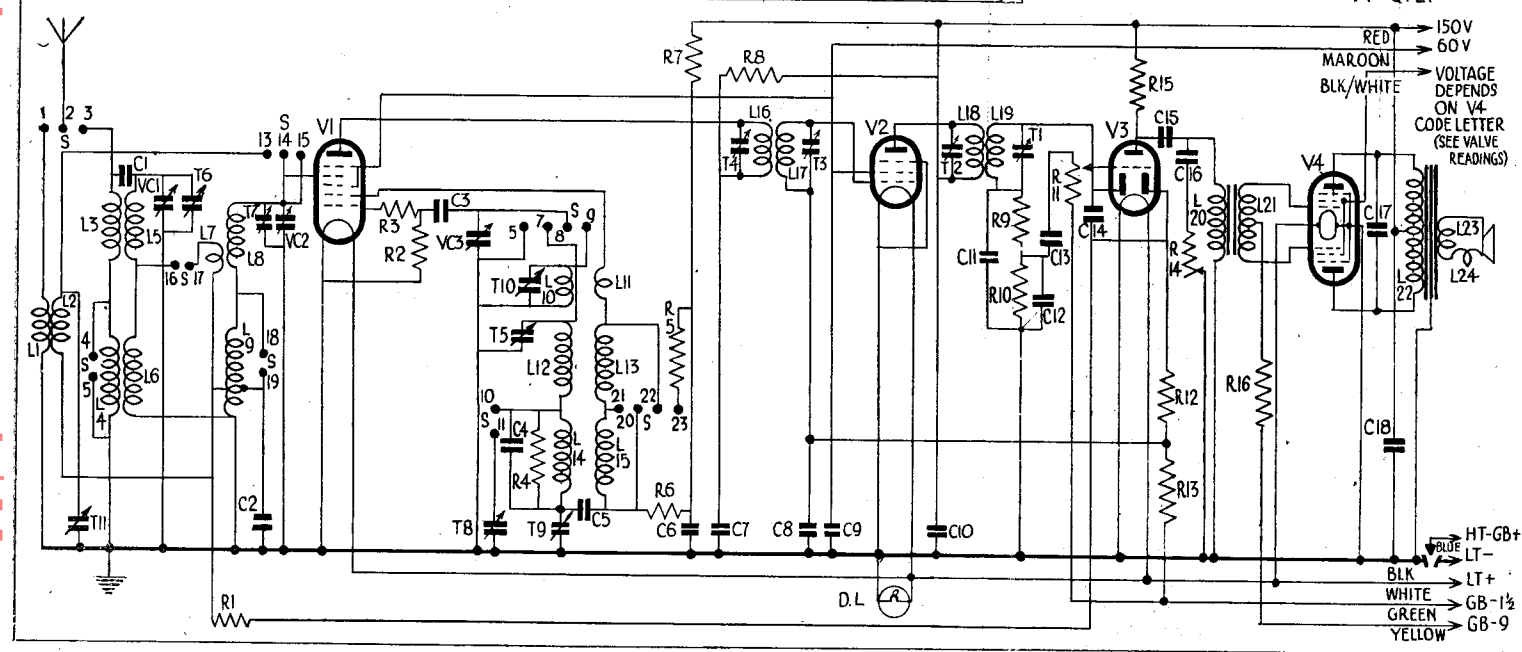

The Ferranti model 1237B in its attractive veneered cabinet. The 1137B is similar, but has a moulded cabinet. A distinctive feature is the vernier tuning scale. The set is a four-valve, three-waveband superhet for battery operation.

RESISTORS

R	Ohms	R	Ohms
1	1 meg	10	1 meg
2	50,000	11	1 meg
3	70	12	2 meg
4	30,000	13	1 meg
5	1,000	14	50,000
6	30,000	15	50,000
7	5,000	16	100,000
8	1,000		
9	100,000		

CONDENSERS

C	Mfd	C	Mfd
1	.000016	10	.1
2	.05	11	.0001
3	.00005	12	.0001
4	.000017/19	13	.02
5	.01	14	.00015
6	2	15	.1
7	.1	16	.03
8	.05	17	.002
9	.1	18	8

WINDINGS

L	Ohms	L	Ohms
1	1.3	13	7.2
2	.06	14	23
3	18	15	8
4	70	16	80
5	4.5	17	80
6	45	18	80
7	.3	19	80
8	4.5	20	485
9	40	21 (total)	21,000
10	.06	22	510
11	.85	23	.2
12	8.5	24	3.8

For more information remember www.savoy-hill.co.uk

FERRANTI MODELS 1137B 1237B

—Continued—

These two diagrams identify the parts on the chassis employed in the Ferranti models 1137B and 1237B. As a four-valve battery superhet the receiver is relatively simple.

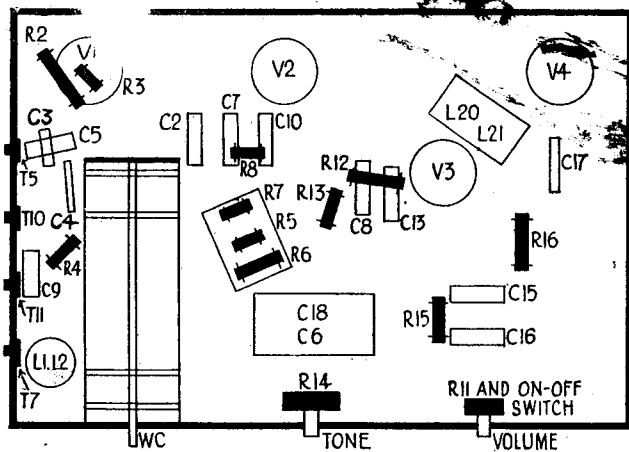
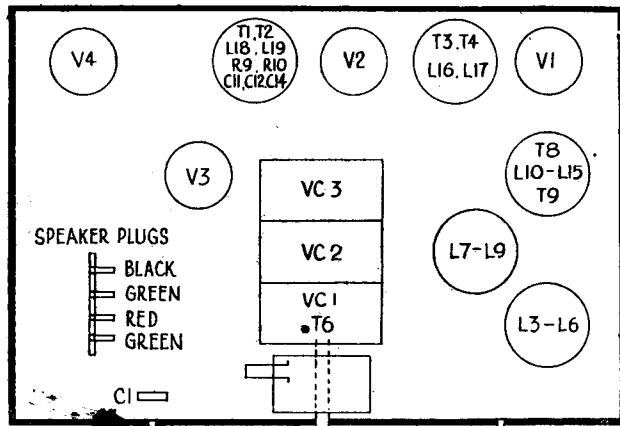

To assist in the rapid identification of small components, resistors are represented in solid black in the above chassis diagram on the left. Condensers are represented in outline.

clockwise), and then slowly clockwise until second maximum peak is obtained. Adjust T6 and T7 for maximum output.

Inject a signal of, and tune receiver to 500 m (600 kc) and adjust T8 for maximum output while rocking gang condenser.

LW Band.—Inject a signal of, and tune receiver to 1807 m (166kc) and adjust T9 for maximum output.

SW. Band.—Adjust receiver to 19.7 m, which is marked on the scale by a black line. Screw T10 to maximum capacity (anti-clockwise) and then slowly turn clockwise until second peak is obtained. Then adjust T11 for maximum output.

HMV 456 : MARCONI 571

Continued from page vi

Tune receiver to 18 m and inject a signal of this wavelength into the aerial and earth sockets. Adjust T5, T6 and T7 for maximum output.

MW Band.—Switch to MW and tune receiver to

viii—RADIO MARKETING SERVICE ENGINEER

300 m. Inject a 300 m signal and adjust T8 and T9 for maximum output. Check calibration on 500 m.

LW Band.—Switch to LW and tune receiver to 1,500 m. Inject a signal of this wavelength and adjust T10 for maximum output, and then T11.

Press-button Circuits.—Connect the aerial and earth to the receiver and tune in the required station on the manual tuner.

Press the button allocated to that station and adjust the oscillator screw above the button so that the index mark coincides with the wavelength required. Adjust carefully until greatest output is obtained, using the tuning indicator as a guide.

Adjust the trimmer below the button to give still greater output and re-adjust oscillator screw to obtain best results.

Note.—Any adjustment of the trimmers across the manual tuning circuits will affect all the settings of the press button circuits and these must be re-adjusted after any ganging has been carried out.

“Don’t you know there’s a war on?”

There are several answers operates. We don’t like we never give our customers arrears of work haunting and that’s one of them. us and breathing down our Short-staffed or not (and neck. We prefer keeping these days who isn’t?) our up to catching up. One Despatch Department deals thing, of course, we can’t with every order the day control—and that’s a delay it’s received. War or peace, in transit. How we wish our twenty-four hour service we could!

Radiospares Ltd.

44 BIRCHINGTON ROAD, LONDON, N.W.6 TEL: MAIDA VALE 9386-7