

# COSSOR 439 BATTERY 3-BAND SUPERHET

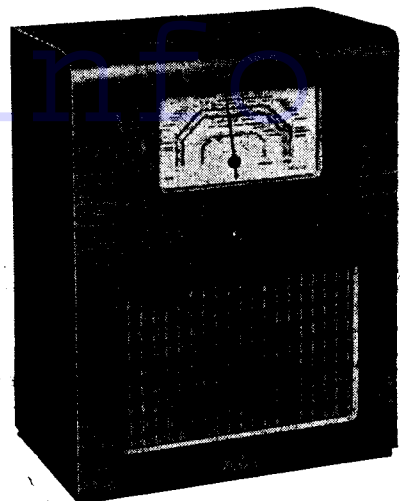

The Coscor 439 is a four-valve battery superhet covering three wavebands and incorporating many of the latest circuit features.

**CIRCUIT.**—The general arrangement of the circuit is orthodox. The aerial is taken through C<sub>1</sub>, an isolating condenser, to the wiper of the first switch which selects the short-, medium- or long-wave aerial windings. The medium- and long-wave grid windings are returned on the lower side to the A.V.C. voltage through the usual condenser and resistance network.

The grid of the first valve is selectively switched to the three tuned circuits and on the short-wave position the A.V.C. voltage is cut out. The long-wave tuned circuit also has an additional fixed trimmer.

A permeability type of I.F. transformer is used in the anode of the frequency changer, V<sub>1</sub>, the secondary being taken to the I.F. amplifier, V<sub>2</sub>, in the normal manner. A.V.C. is supplied through a separate decoupling circuit.

Another permeability tuned I.F. transformer links V<sub>2</sub> to the demodulating diode of V<sub>3</sub>, a combined double diode triode. The second diode is used for A.V.C., being condenser fed from the anode of V<sub>2</sub>.

The signal diode load comprises the volume control. In order to isolate the grid of the triode section a coupling condenser is used between the slider, and the grid has a separate return path resistance which is connected to a potentiometer network providing the necessary bias.

A resistance-capacity network forms the low-frequency coupling to the output valve, V<sub>4</sub>, the tone control being across the grid circuit. A correction circuit on V<sub>4</sub> consists of a fixed condenser between the anode and earth and a resistance

capacity combination between the anode and the plus H.T. line.

**Chassis Removal.**—Removal of the chassis is an easy matter. After removing the four knobs on the front the complete chassis can be removed by releasing two bolts at the back which retain a locking-bar. The locking-bar has two spigots which locate with rubber grommets at the back of the chassis, two further spigots being mounted on the inside of the cabinet.

After releasing the bar the chassis withdraws from the spigots, and disconnection of the speaker plug enables it to be completely removed.

## VALVE READINGS

| V. | Type.     | Electrode.          | vólts. | ma.  |
|----|-----------|---------------------|--------|------|
| 1  | 220 TH    | Anode .. ..         | 117    | .3   |
|    |           | Screen .. ..        | 56     | .8   |
|    |           | Osc. anode (SW)     | 49     | 2.9  |
|    |           | Osc. anode (L & MW) | 29     | 1.3  |
| 2  | 210 VPA   | Anode .. ..         | 117    | 1.35 |
|    |           | Screen .. ..        | 53     | .6   |
| 3  | 210 DDT   | Anode .. ..         | 66     | .4   |
|    |           | Screen .. ..        | 111    | 4.2  |
| 4  | 220 OT .. | Anode .. ..         | 117    | 1.0  |
|    |           | Total H.T. (L & MW) | —      | 9.95 |

## RESISTANCES

| R. | Purpose.                  | Ohms.   |
|----|---------------------------|---------|
| 1  | V1 screen decoupling      | 70,000  |
| 2  | V1 osc. anode load (part) | 50,000  |
| 3  | V1 osc. anode load (part) | 20,000  |
| 4  | V1 osc. grid leak         | 40,000  |
| 5  | V1 A.V.C. decoupling      | 3 meg.  |
| 6  | V2 A.V.C. decoupling      | 3 meg.  |
| 7  | V2 screen decoupling      | 100,000 |
| 8  | H.F. filter               | 50,000  |
| 9  | Volume control            | 500,000 |
| 10 | V3 grid leak              | 1 meg.  |
| 11 | A.V.C. diode load         | 2 meg.  |
| 12 | V3 anode load             | 100,000 |
| 13 | Tone control              | 250,000 |
| 14 | V4 grid leak              | 1 meg.  |
| 15 | V4 grid stopper           | 100,000 |
| 16 | L.F. filter               | 25,000  |
| 17 | Bias pot. (part)          | 250     |
| 18 | Bias pot. (part)          | 150     |

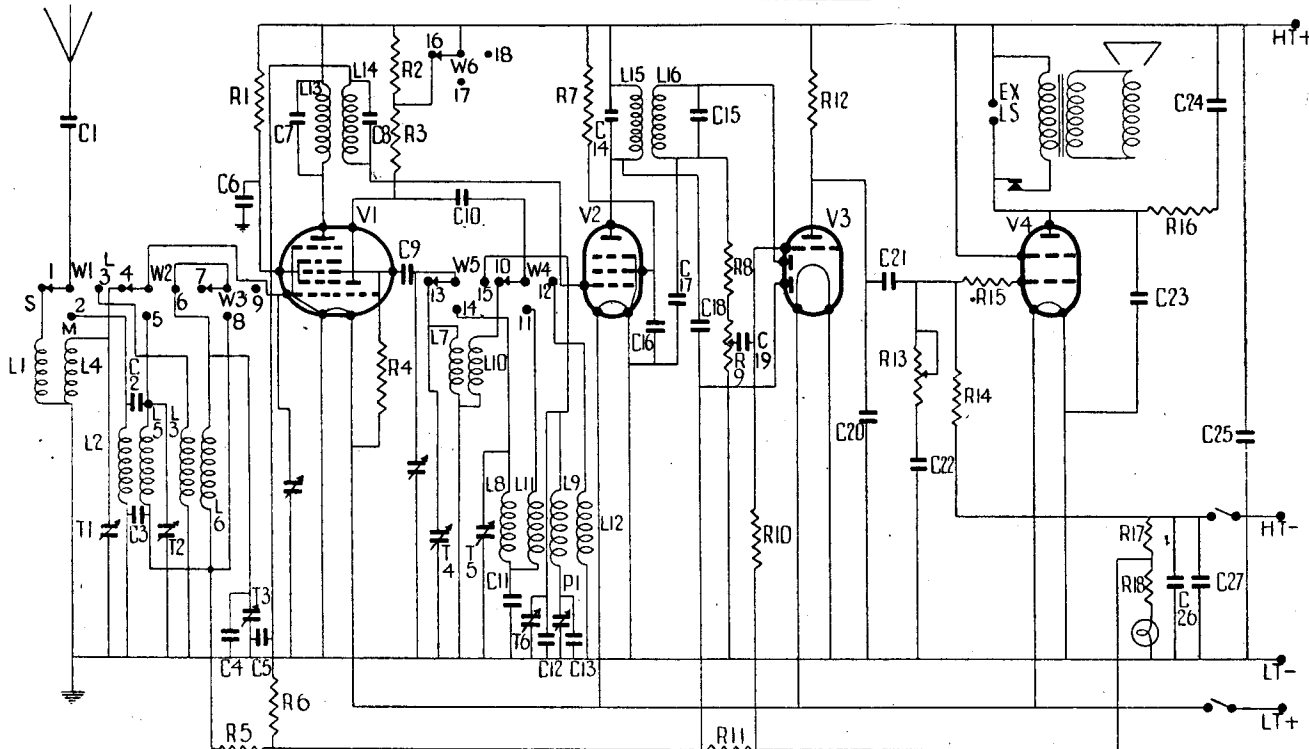

A triode-hexode frequency changer is followed by a pentode I.F. amplifier, a double-diode triode and a tetrode output valve. Iron-core I.F. transformers are employed and bias is automatic.

For more information remember

Special Notes.—A 3.5 volt 150 m.a. M.E.S. bulb is used as a fuse in the common H.T. circuit and is accessible from the top of the chassis.

Permeability-tuned I.F. transformers are used and condensers C7 and C8 and C14 and C15, which tune the primaries and secondaries, are located in the transformer cans.

When making voltage or other valve tests it should be realised that V2, the I.F. amplifier, has a top anode and not a top grid.

Should it be necessary to carry out any repairs to the coil unit, by disconnecting a number of leads and withdrawing the switch operating bar the whole coil assembly can be removed by taking out the retaining bolts, which have nuts on the top of the chassis.

Wavechange Switches.—In this receiver two switch wafers are used, each having three wipes and three contacts. The wafer in the aerial compartment contains the aerial and tuned circuit selector, and also a unit which short circuits the long-wave coil in the medium-wave position, there being two blank contacts on this unit.

The other wafer, which is in the

oscillator compartment, provides for the switching on the grid and anode circuits and also a short circuit position on the third unit which cuts out part of the anode feed resistance on the short-wave band.

### Alignment Notes

I.F. Circuits.—First connect an output meter across the primary of the speaker transformer, switch receiver to M.W. band, turn gang to maximum capacity, volume to maximum and tone to "high" position. Connect a service

| WINDINGS (D.C. Resistances) |          |        |  |
|-----------------------------|----------|--------|--|
| L.                          | Ohms.    | Range. | Where measured.                        |
| 1                           | .6       | S.W.   | C1 and chassis                         |
| 2                           | 23       | M.L.   | C1 and chassis                         |
| 3                           | 135      | L.W.   | C1 and chassis                         |
| 4                           | Very low | S.W.   | Grid V1 and chassis                    |
| 5                           | 2.3      | M.W.   | Grid V1 and (R5 and C3)                |
| 6                           | 15.3     | L.W.   | Grid V1 and (R5 and C3)                |
| 7                           | Very low | S.W.   | C9 and chassis                         |
| 8                           | 4.5      | M.W.   | C9 and T5                              |
| 9                           | 13.6     | L.W.   | T6 and C13                             |
| 10                          | .2       | S.W.   | C10 and chassis                        |
| 11                          | 2.2      | M.W.   | C10 and C11.                           |
| 12                          | 6.2      | L.W.   | C10 and chassis                        |
| 13                          | .7       | —      | H.T. plus and V1 anode                 |
| 14                          | 7.1      | —      | V2 grid and (R6 and C5)                |
| 15                          | 17.8     | —      | V2 anode and plus H.T.                 |
| 16                          | 17       | —      | V3 demodulator diode and* (R8 and C17) |
| O.T. primary                | 1,280    | —      | V4 anode and plus H.T.                 |

### CONDENSERS

| C. | Purpose.                        | Mfds.   |
|----|---------------------------------|---------|
| 1  | Aerial series                   | .0005   |
| 2  | M.W. top coupling               | .00001  |
| 3  | V1 A.V.C. decoupling            | .05     |
| 4  | L.W. input fixed trimmer        | .00003  |
| 5  | V2 A.V.C. decoupling            | .05     |
| 6  | V1 series decoupling            | .1      |
| 7  | I.F.T.1 fixed primary trimmer   | .000053 |
| 8  | I.F.T.1 fixed secondary trimmer | .000058 |
| 9  | V1 osc. grid                    | .00005  |
| 10 | V1 osc. anode coupling          | .0005   |
| 11 | M.W. fixed padder               | .000598 |
| 12 | L.W. osc. fixed trimmer         | .00005  |
| 13 | L.W. osc. fixed padder          | .00014  |
| 14 | I.F.T.2 primary fixed trimmer   | .000053 |
| 15 | I.F.T.2 secondary fixed trimmer | .00007  |
| 16 | V2 series decoupling            | .1      |
| 17 | H.F. bypass                     | .00005  |
| 18 | A.V.C. coupling                 | .00005  |
| 19 | L.F. coupling                   | .05     |
| 20 | V3 anode shunt                  | .0002   |
| 21 | L.F. coupling                   | .01     |
| 22 | Tone control                    | .01     |
| 23 | V4 anode shunt                  | .001    |
| 24 | V4 tone filter                  | .002    |
| 25 | H.T. shunt                      | .2      |
| 26 | Bias shunt                      | 20      |
| 27 | Bias H.F. shunt                 | .1      |

Right, the switch banks of the 439 with the oscillator section at the top. Below, the under-chassis layout diagram.

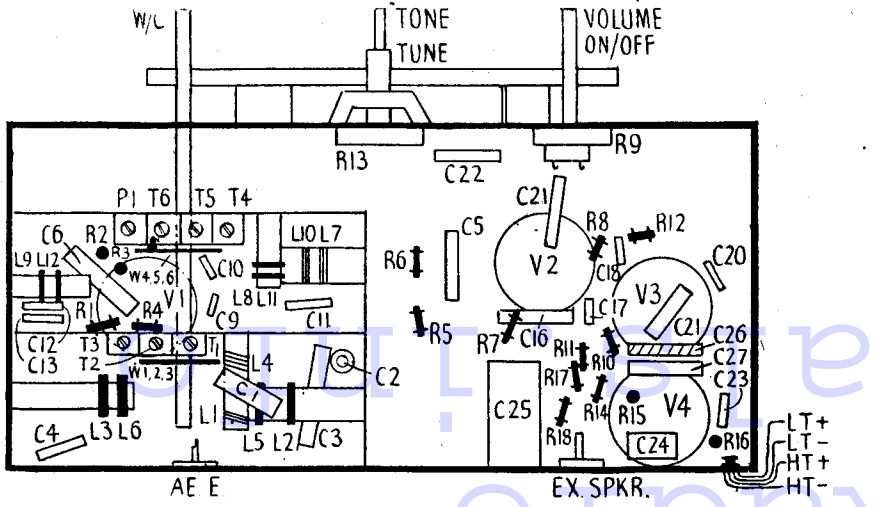
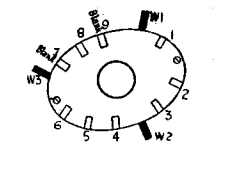
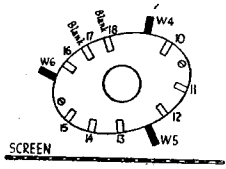

## Cossor 439 on Test

MODEL 439.—For battery operation, requiring 120-volt H.T. battery (double-capacity recommended) and 2-volt 45-a.h. (Cossor E245 or 370) accumulator. Price, £7 15s., without batteries.

DESCRIPTION.—Four-valve battery superhet with manual tuning and covering three wavebands.

FEATURES.—Full-vision horizontal scale with calibrations in wavelengths and station names on medium and long bands and wavelengths and kilocycles on the short waves. Concentric controls for tuning and tone and separate knobs for wave selection and combined volume control and master switching. Sockets for aerial and earth and a switched extension speaker socket operating on the high impedance side. Permeability tuned I.F. transformers, fuse lamp in the H.T. circuit and a special output valve.

LOADING.—H.T., 9.95 ma.; L.T., 0.55 amp.

### Sensitivity and Selectivity

SHORT WAVES (16-52 metres).—Very good sensitivity for a battery set well maintained over the band. Easy handling.

MEDIUM WAVES (190-580 metres).—Excellent gain and adequate selectivity. Small local station spread and well maintained gain. Clean background.

LONG WAVES (340-2,150 metres).—Excellent selectivity and good gain, with all main stations easily received. Very little interference on Deutschlandsender.

### Acoustic Output

Very good volume for a battery set, with a moderate consumption. The tone is well balanced, with a reasonable amount of upper registers and a not too vigorous tone control. Speech is very pleasing and there is excellent freedom from colouration.

oscillator between the top grid cap of V1 and chassis.

Tune the service oscillator to 465kc. and adjust first the iron cores of I.F.T.2 and then I.F.T.1 for maximum response. Reduce the input from the service oscillator as the circuits come into line to keep the signal below A.V.C. point.

The cores are sealed with wax compound and should be resealed after adjustment.

Signal Circuits.—The pointer should coincide with the last calibration mark on the scale when the gang is at maximum. Connect the service oscillator to the aerial and earth sockets via a dummy aerial.

Short Waves.—Tune set and oscillator to 18 mcs. and adjust T4 and T1 for maximum response.

Medium Waves.—Tune set and oscillator to 214 metres (1,400 kc.) and adjust T6 and T2 for maximum.

Long Waves.—Tune set and oscillator to 1,200 metres (250 kc.) and adjust T6 and T3 for maximum response. Tune set and oscillator to 1,875 metres (160 kc.) and adjust P1 for maximum, simultaneously rocking the gang.