

BURNDEPT CN201, 225, 226, 231

Four-valve, plus rectifier, two-waveband superhets, marketed 1935-6. Model CN225 is a radio-gram; others are table models. All are suitable for mains supplies of 200-250-volts, 50-100-cycle AC. Made by Burndept, Ltd., Erith.

Circuit.—A tapped primary, inductively coupled, bandpass circuit feeds the grid of the pentagrid converter valve V1. A mains aerial is provided via C1. Standing bias is provided by R2 decoupled by C3. HT to the oscillator section of V1 is cut off on gram by S8. Output of V1 is coupled by normal IFT to V2, an HF pentode, and thence by second IFT to V3, a double-diode valve.

Signals developed across the diode load R16 are fed to volume control R12 via C15.

C16 feeds the AVC diode and voltages across loads R14 and R15 control V1 and V2 grid circuits. R7 provides standing bias for V2.

The AVC diode has delay volts by reason of cathode resistance R10, which also carries "bleeder" current from V2 screen pot, R8-R9.

Varying anode currents due to AVC on V1 and V2 are made to operate a tuning meter in the common HT supply. A shunt, R6, is across the meter which is decoupled by C10.

From R12 audio signals proceed to the grid of V4, a pentode output valve, which has a constantly variable tone control consisting of C18 and R19. A low-impedance speaker is transformer coupled to output of V4, but external speakers must be of high-impedance or have suitable matching transformers. V4 is biased by R18 decoupled by C17.

HT is supplied by a normal circuit comprising a full-wave rectifier, V5, field coil of speaker and smoothing condensers C20 and C21.

In models 201, 226 and 231 the PU input is connected directly across the volume control, R12, but in the model 225RG extra LF amplification is obtained by feeding the pick-up into the grid of V2 via a pair of switch contacts. S8 breaks the IFT secondary circuit to the grid of V2 instead of the HT to the oscillator as in the other models.

A 10,000-ohm resistance is connected between the primary of IFT2 and the tuning meter, and the LF voltages across this resistance are coupled by a .01 mfd condenser to the junction of C15 and R12. A limiting resistance of .25 meg is connected between the .01 mfd condenser and R12, and a tone correction condenser of .002 mfd is connected between chassis and the junction of the 10,000-ohm resistance and IFT2.

In all other respects the circuits are similar.

GANGING

IF Circuits.—A few early instruments have 117.5 kc IFs, but majority of models trim to 130 kc. The latter will be recognised by a white spot on the coil cans.

Top view of chassis showing layout of all trimmers, valves and coils.

The circuit (below) employs a double diode followed by a high-slope pentode. The set covers two wavebands.

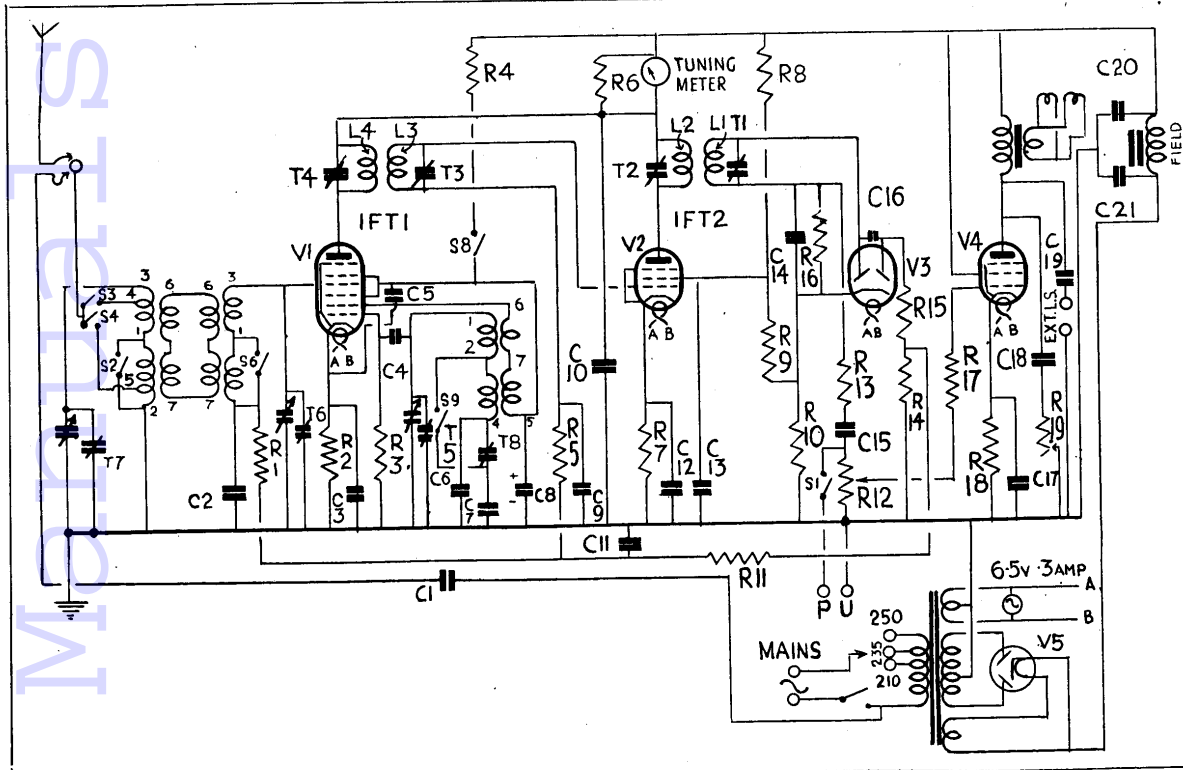
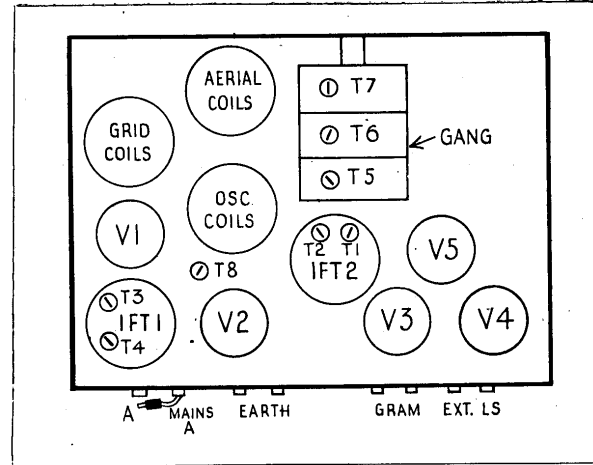

CONDENSERS

C	Mfds	C	Mfds
1	.0001	12	.1
2	.1	13	.1
3	.1	14	.0001
4	.001	15	.01
5	.1	16	.0001
6	.0005	17	.50
7	.01	18	.1
8	.8	19	.5
9	.1	20	.16
10	.1	21	.8
11	.1		

In earlier issues of the table models, C20 and C21 were each of 6 mfd.

RESISTANCES

R	Ohms	R	Ohms
1	100,000	11	.25 meg
2	250	12	.5 meg
3	50,000	13	100,000
4	30,000	14	1 meg
5	100,000	15	.5 meg
6	5,000	16	1 meg
7	200	17	.25 meg
8	10,000	18	.15
9	8,000	19	.25 meg
10	700		

The resistance of the LS field winding in the earlier models was 2,500 ohms, but all later models are fitted with speakers having 2,000 ohm fields.

VALVE READINGS

V	Type	Electrode	Volts	Ma
1	FC4	Anode	240	3
		Screen	85	5
		Osc anode	85	2
2	VP4A	Cathode	2	10
		Anode	240	4.5
3	2D4A	Screen	100	3.5
		Cathode	2	8
4	PEN4VB or COSSOR	Anode	10	14
		Anode	240	33
5	42MP PEN R2 Rectifier	Screen	240	3
		Cathode	6	36
		Cathode	420	68/70

Above readings were with 2,500 ohms speaker field; readings will be higher on models with 2,000 ohms fields.

Instability with 6L6 Replacement

IN receivers using a 6L6 metal valve it will be found that replacement by a glass type invariably causes instability. This is due to feed-back and may be cured by using a 6F6G glass type instead of the 6L6. The former is a pentode and the latter a beam power tetrode, but any drop in volume is not noticed.