

# BURNDEPT SUITCASE 274 PORTABLE

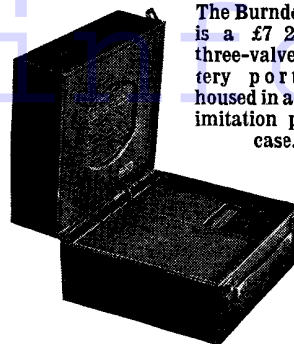

The Burndept 274 is a £7 2s. 6d. three-valve battery portable housed in a brown imitation pigskin case.

**CIRCUIT.**—A frame aerial is incorporated and is wound in the lid of the receiver, which also contains the speaker. The signal passes to V1, a tetrode.

The output of V1 is inductively and capacity coupled to the grid of V2, also a tetrode, acting as the detector. Reaction is obtained from the anode in the usual manner.

The rectified output is resistance and capacity coupled to V3, an L.F. pentode, and thence to the speaker.

The battery equipment consists of a Vidor H.T. battery type 17872 and a Vidor accumulator.

**Special Notes.**—A switch is provided on the tuning panel for switching off the dial light when tuning is accomplished. The dial light is mounted in a screw-in holder and is rated at 2.6 volts and consumes .3 ampere.

The frame aerial trimmers are under the paper seal on the speaker baffle. It is seldom necessary to disturb these trimmers.

**Chassis Removal.** — Disconnect the batteries and remove the case. Undo the two screws fixing the panel to the chassis and remove three control knobs, which are fixed by grub screws, and then

unscrew the dial light on/off switch. The panel can then be detached and the side panel also taken away.

The two screws on the face of the chassis must be removed. Next turn the set on its side and remove the two screws thereon. The chassis is then available for all service requirements.

If it is found necessary to effect repairs to the speaker, the four fixing screws observed on the outer surface of the lid must be removed.

## Circuit Alignment Notes

A signal generator, covering the ranges of 200 to 550 and 1,000 to 2,000 metres, is necessary, and also a coil of about 60 turns for injection of the signal into the receiver. This coil is stood on edge facing the frame aerial and some distance from it. The signal generator is connected directly across this coil.

Alignment should be carried out with the chassis removed from the cabinet, as already described.

A trimmer on the lower section of the gang will be noticed; this is the medium

wave anode trimmer. The long wave anode trimmer is the one connected to the lug on the left-hand side of the chassis. The frame aerial trimmers are underneath the name tab on the speaker baffle.

See that the tuning indicator travels to last division on the scale (above 550 metres) with gang condenser in maximum position. If not, adjust the pointer by loosening the grub screw on the wire drum and rotating the drum.

**Medium Waves.**—Inject 270 metres (1,112 kc.) from the signal generator into

### RESISTANCES

R.	Purpose.	Ohms.
1	V1 grid leak .. .. .	500,000
2	V2 screen decoupling .. .	500,000
3	V2 grid leak .. .. .	2 meg.
4	V2 anode load .. .. .	250,000
5	V3 grid leak .. .. .	500,000
6	V3 grid stopper .. .. .	100,000

### CONDENSERS

C.	Purpose.	Mfds.
1	V1 screen decoupling .. .	.1
2	V1 grid isolating condenser .. .	.0001
3	H.T. reservoir .. .. .	8
4	2 grid condenser .. .. .	.0001
5	V2 screen decoupling .. .	.1
6	H.F. by-pass .. .. .	.0002
7	H.F. by-pass .. .. .	.0002
8	L.F. coupling .. .. .	.01
9	Pentode compensator .. .	.001

### VALVE READINGS

No signal. No reaction. Volume maximum. New batteries.

V.	Type.	Electrode.	Volts.	Ma.
1	All Mullard. VP2B met. (7)	Anode ..	99	1.2
		Screen ..	65	inaccess-ible.
2	VP213 met. (7)	Anode ..	31	inaccess-ible.
		Screen ..	20	inaccess-ible.
3	PM22A (5)	Anode ..	98	3.7
		Screen ..	99	.6

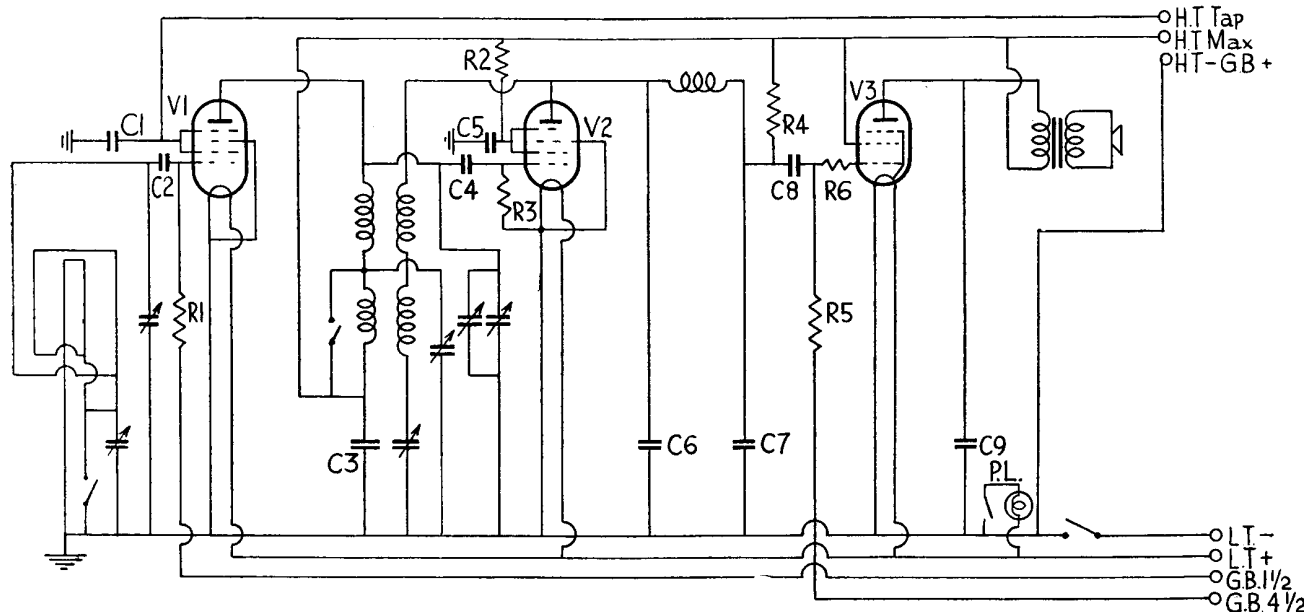

The circuit of the 274 is the essence of simplicity, and service should present few problems. Two H.F. pentodes and an output pentode are used in a perfectly orthodox arrangement.

For more information remember  
www.savoy-hill.co.uk

the coil previously mentioned, and place it some distance away from the back of the receiver. Tune this signal in on the receiver, and, at the same time, advance the reaction control as far as possible without making the set actually oscillate.

Note whether the signal is tuned at the maximum strength at the 270 metres mark on the scale, and, if not, adjust the medium wave anode trimmer until it does. Then, keeping the reaction advanced as much as possible, adjust the medium wave aerial trimmer on the frame aerial (the right-hand one) and note when the maximum output is obtained on the output meter.

As the circuits come into line the receiver may start to howl, and when it does this the reaction control should be turned back until the howling ceases.

The medium wave aerial trimmer should continue to be adjusted until a maximum reading is shown on the output meter.

The main tuning control should be swung slightly during the previous operation to make sure that the circuits are in resonance with the 270 metre signal.

Medium wave calibration should be checked at various points on the medium wave range.

**Long Waves.**—Switch over to the long waves on the receiver and to 1,500 metres (250 kc.) on the signal generator. Adjust the output of the generator until an output that is just audible is heard on the receiver when the signal is tuned in.

Adjust the long wave anode trimmer under the chassis until the long wave calibration is correct, and then adjust the long wave aerial trimmer for maximum

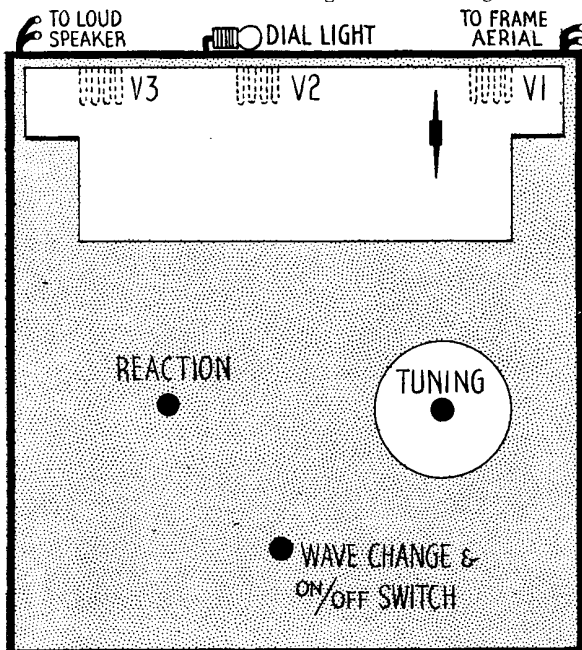

These two diagrams show the constructional details of the Burndept portable. The one on the left shows how the controls are arranged and the relation of the three valveholders to the tuning scale.

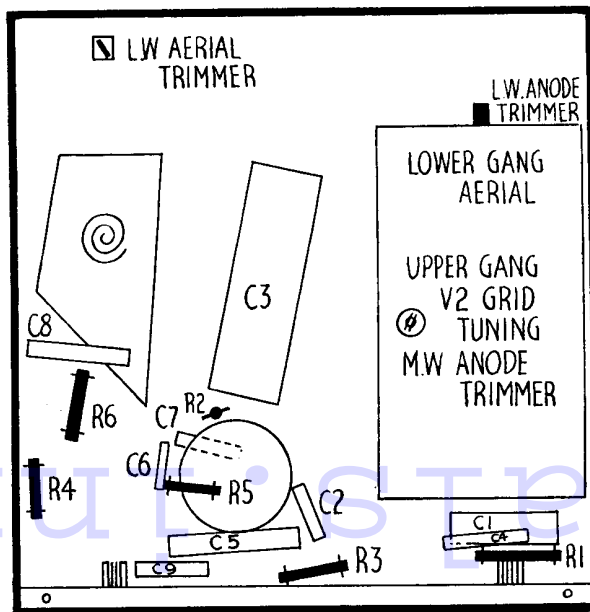

Right, is the layout of the interior of the 274 chassis. The small parts are suspended in the wiring and the circuits are easily traced.

## Burndept 274 on Test

**MODEL 274.**—Portable set for operation with batteries.

**DESCRIPTION.**—A two-wave band battery suitcase portable.

**FEATURES.**—Controls for tuning, reaction, wave selection and pilot lamp. Full vision scale, with wavelength and name calibration. Permanent magnet speaker in lid with opening on either side, covered by gauze.

**LOADING.**—9.2 m.a. H.T.; 0.4 L.T. or 0.64 with dial light.

**PRICE.**—£7 2s. 6d.

### Sensitivity and Selectivity.

**MEDIUM WAVES (200-600 metres).**—Gain and selectivity quite good for the simple valve combination and small frame. Main stations received with careful handling, selectivity adequate for all ordinary purposes, improved by the directional properties of the aerial. Reaction fairly free from overlap trouble and not too critical.

**LONG WAVES (900 to 2,200 metres).**—Similar performance to the medium waves, the main strong stations being easily received without overlap. No appreciable backlash in reaction control.

### Acoustic Output.

Sufficient for small room, with reasonable quality. There is naturally a certain amount of colouration, but the performance on the whole is quite good.

output on the output meter, swinging the gang slightly as before until an optimum output is obtained.

Reaction, as before, should be advanced to the point where the receiver is approaching oscillation but is definitely not oscillating.

The aerial trimmers should trim the frame at a point equal to about half of their capacity, and care should be taken that no false maximum reading is obtained on the output meter when the trimmers are at one end or the other of their travel.

If the leakage from the generator is too large and the output too great, remove the injection coil to a position further away from the receiver.

### Replacement Condenser

**A REPLACEMENT** for C3, the 8 mfd. electrolytic connected as a reservoir across the maximum H.T. supply, is available from A. H. Hunt, Ltd., of Garratt Lane, Wandsworth, London, S.W.18. List number 3490, this condenser retails at 2s. 6d.

### A PILOT-LAMP TIP

It is not often realised that pilot lamps vary very considerably in resistance, especially in the cheaper makes. Reliable bulbs will always bring rewards in customer satisfaction.

Where two are used in series, it is always advisable to select a pair of as nearly as possible the same D.C. resistance. This simple precaution gives a surprising reduction in pilot lamp troubles.