

AMBASSADOR 6778 FOUR-BAND SIX

CIRCUIT.—The H.F. amplifying valve V1, a pentode, is fed by aerial transformers on all bands and controlled by A.V.C. only on the medium and long wavebands.

Inter-valve transformers effect the coupling to the triode-hexode frequency changer V2, the secondaries of the transformers being tuned. A.V.C. is not applied to the valve on the short wavebands to obviate drift. The oscillator section follows standard practice, and regeneration modifier resistances are included.

An I.F. transformer of the adjustable iron-core type provides the coupling to the I.F. amplifying valve V3, another H.F. pentode. A further I.F. transformer of similar construction feeds one of the diodes of V4, a double-diode triode.

Connection to the diode load of V4 is effected via an H.F. filter circuit. The rectified potentials feed the A.V.C. network and also the triode grid of V4 via

an L.F. coupling condenser, manual volume control and grid stopper resistance.

Bias to the triode grid of V4 is obtained from a 1.5-volt dry cell.

V4 is resistance-capacity coupled to the pentode output valve V5. R17 and C25 provide a treble-cut tone control, and a pentode compensator condenser C29 supplements the tone control.

Mains equipment consists of a mains transformer, a full-wave rectifying valve V6, electrolytic smoothing condensers, and a smoothing choke (the speaker field).

Receiver Chassis Removal.—Remove the back and the four grub-screw secured control knobs. Remove the two chassis-fixing nuts from the base and withdraw bolt from chassis. Unsolder the lead to the earthing tag on the chassis.

The chassis may then be withdrawn to the extent of the power-supply cable. The seven-pin plug can, of course, be withdrawn from its socket on the receiver chassis.



Reception on two short wavebands together with medium and long is provided by the Ambassador 6778, which retails at 12 gns.

Power Pack Removal.—Remove the two 4B.A. nuts from the flanges of the power-pack chassis. This is best effected by turning the cabinet on its end and unscrewing the two brass 4B.A. bolts from the base while holding the nuts inside the cabinet. Then remove the single wood screw securing the flange to the base of the cabinet, the supply-cable plug from its socket on the receiver chassis deck (if this is still in position), and the four-pin speaker cable plug.

Special Notes.—Sockets at the rear of the chassis near the aerial and earth sockets are for connecting a pick-up.

The separate power pack chassis is connected to the receiver by means of a plug and the speaker is similarly connected to the power pack chassis.

The two dial lights are rated at 6.2 volts .3 amp, and have M.E.S. bases.

The mains adjustment device consists of three sockets on the mains transformer marked with voltage values, and into one of these a threaded member is screwed.

C15 and C16 are contained inside I.F.T.1 and C20 and C21 are in I.F.T.2. In our particular chassis C2, C3, C14, C18, C28, R4 and R12 were missing, whilst C18 was .0001. We understand that the circuit has been modified. R6 is in the top grid cap connector of V2. In some chassis the trimmers and coils may be in slightly different positions, but the coils can be easily identified.

A 1.5 volt dry cell provides the bias to the grid of the triode section of V4. The cell is G.W.Z. Mono cell, No. 4.

Sockets for an A.C. gramophone motor are provided on the power pack chassis.

WINDINGS (D.C. Resistances)

L.	Ohms.	Range.	Where measured.	L.	Ohms.	Range.	Where measured.
1	.2	S.W.1	Aerial socket and chassis.	15	3.8	M.W.	H.F. gang and C5.
2	.5	S.W.2	Aerial socket and chassis.	16	12.1	L.W.	H.F. gang and C5.
3	10	M.W.	Aerial socket and chassis.	17	Below .1	S.W.1	Osc. gang and C11.
4	113	L.W.	Aerial socket and chassis.	18	.26	S.W.2	Osc. gang and C12.
5	Below .1	S.W.1	Top grid V1 and chassis.	19	3	M.W.	Osc. gang and P2.
6	.2	S.W.2	Top grid V1 and chassis.	20	7	L.W.	Osc. gang and P1.
7	3.7	M.W.	Top grid V1 and C1.	21	.4	S.W.1	C10 and C11.
8	12.8	L.W.	Top grid V1 and C1.	22	25.7	S.W.2	C10 and C12.
9	.3	S.W.1	Anode V1 and H.T. line.	23	77.7	M.W.	C10 and P2.
10	.7	S.W.2	Anode V1 and H.T. line.	24	71.7	L.W.	C10 and chassis.
11	2	M.W.	Anode V1 and H.T. line.	25	2.3	—	Anode V1 and H.T. line.
12	6.7	L.W.	Anode V1 and H.T. line.	26	2.3	—	Top grid V3 and R10.
13	.1	S.W.1	H.F. gang and chassis.	27	2.1	—	Anode V3 and H.T. line.
14	.2	S.W.2	H.F. gang and chassis.	28	2.1	—	R14 and diode V4.
				29	1070	—	Red and yellow leads speaker panel.
				O.T. prim.	360	—	Blue and yellow leads speaker panel.
				M.T. prim. (300v)	24.5	—	Mains plug pins.
				Total H.T.	303	—	Anode pins V6.

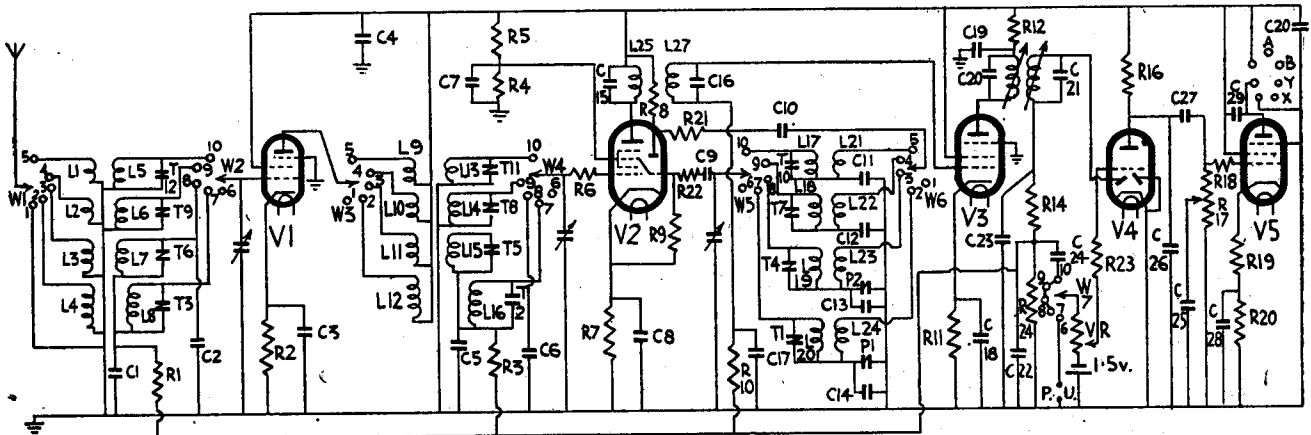

The main receiver portion of the Ambassador circuit, above, has an oscillator section following standard practice, while A.V.C. is not provided on short waves to obviate drift.

For more information remember
www.savoy-hill.co.uk

Philips Model 660A

(Continued from opposite page.)

keep the driving wire D taut. Then tighten up screw A, making sure the tuning does not alter.

Repeat with a 250-metre (1,200 kc.) signal, and if the pointer does not tally, only adjust A to the extent of half the amount of deviation, on the other side of 250 metres.

Then loosen screw B, turn the pointer spindle or shaft E until the pointer reads 250 metres, tighten screw B and check at 510 metres.

If screw A cannot be moved far enough, the drum G should be turned slightly. Remove control knobs, loosen bottom chassis-securing bolts and the two grub-screws holding the drum on the spindle, tilt the chassis slightly to the rear and then turn the drum (taking care the spindle does not move). Then refix the drum, and, before proceeding, resecure the chassis in the cabinet.

Station Key Adjustment.—Pull off the cap from the station key which has to be adjusted, pull out the tuning knob, thereby releasing all keys, and carefully tune in the desired station.

Depress the key and insert the special screwdriver. If, when the key was depressed the desired station disappeared or another station was heard in its place, turn the screwdriver to the left until the desired station is again heard and remains unaffected by further anti-clockwise rotation of the screwdriver. Now turn the screwdriver to the right until the station is slightly detuned, as shown by a decrease of the green star in the tuning indicator.

If when the key was first depressed the desired station remained unaffected, turn

the screwdriver to the right until the station is slightly detuned as shown by the tuning indicator.

Swing the wavelength pointer to "Key-board tuning" position (lowest wavelength) and make a final adjustment with the screwdriver until the desired station is accurately tuned in on the tuning indicator.

Station Key Notes.—When using the special screwdriver, care must be taken not to press against the key, otherwise the latter will be depressed beyond its normal operating position and an incorrect tuning adjustment will result.

Although each of the keys can be adjusted to any wavelength in the medium and long wavebands, it is desirable to arrange that the shortest wavelength stations are allocated to the keys in the centre.

Your Experiences . . .

YOUR experiences of tracing elusive faults and effecting difficult repairs may be of assistance to other engineers. Why not send useful tips along for publication, at the usual rates, in *Service Engineer*?

Hints are of most value if the line of reasoning which solves a problem is explained. Remember this when writing.

Letters are invited, also, on what articles should be published in *Service Engineer* and how set reviews can be improved.

Address your letter to The Editor, WIRELESS RETAILER AND BROADCASTER, 29, Bedford Street, London, W.C.2.

Decca Model PT-B

(Continued from page 27.)

The wavelength pointer should be vertical when the gang condenser is at maximum. Connect the service oscillator to the aerial and earth sockets via a dummy aerial. Only feed sufficient input to obtain reliable peaks.

Medium Waves.—Depress M.W. manual button, tune set and oscillator to 200 metres (1,500 kc.) and adjust T1 and then T2 for maximum response.

The padding is fixed, but check calibration at 550 metres, compensating slightly with T1 if very much out.

Long Waves.—Depress L.W. manual button, tune set and oscillator to 1,000 metres (300 kc.) and adjust T3 and then T4 for maximum.

The L.W. padding is fixed, but check calibration at 2,000 metres, compensating slightly with T3 if very much out.

Press-button Alignment.—Remove service oscillator and output meter and connect an aerial and earth system. Place the cabinet on its side so as to obtain access to the trimmer panel through the false bottom.

A choice of four medium-wave and two long-wave stations is obtained without recourse to wavechange switches. A button, when pressed automatically sets itself to the correct waveband.

Each button should be calibrated on the actual station it is to receive. For example, press the button inscribed London Regional, adjust the corresponding oscillator trimmer (see sketch) to bring in the station, and then adjust the corresponding aerial trimmer.

Ambassador 6778 Four-band Six

Valve positions and other components are identified by this top-of-chassis layout diagram of the model 6778. Below are details of the switch banks, one to four, from left to right.

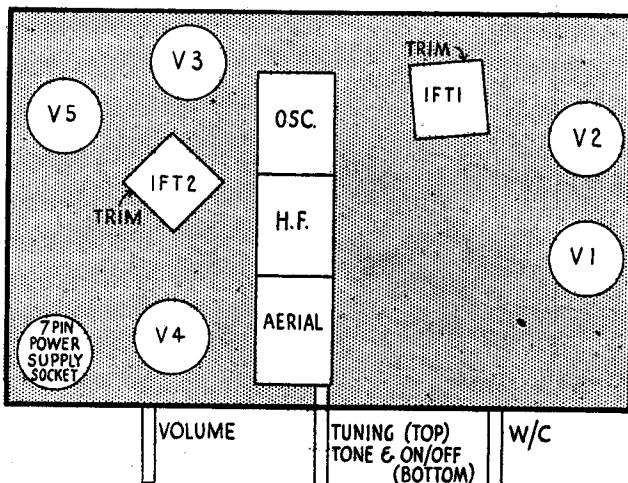

A replacement for the block containing C31 and C32 is available from A. H. Hunt Ltd. Unit list number 3859, it retails at 10s. 6d.

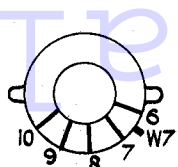
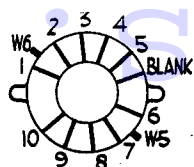
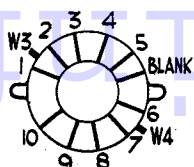
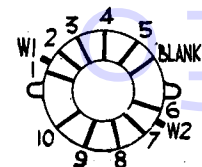

(Continued from page 21.)

signal, tune in on receiver and adjust T5 and T6 for maximum.

S.W.2 (34-96 metres).—Tune set and oscillator to 40 metres (7.5 mc.), screw T7 right up and then unscrew until the second peak from "tight" is heard. Then adjust T8 and T9 for maximum.

Check at 90 metres (3.3 mc.) to ensure that the correct peak has been selected.

S.W.1 (12-35 metres).—Tune set oscillator to 13.9 metres (21.5 mc.), screw T10 right up and then unscrew until the second peak from "tight" is heard.

Then tune set and oscillator to 20 metres (15 mc.) and adjust T11 and T12 for maximum response. Check at 31 metres to ensure that the correct peak has been selected.

VALVE READINGS

No signal. Volume maximum. M.W. min. cap 200 volt A.C. mains.

V.	Type.	Electrode.	Volts.	Ma.
	(Mazda)			
1	AC/VP2	Anode ..	245	10.6
		Screen ..	245	3
2	AC/TH1	Anode ..	245	1.6
		Screen ..	75	5.8
		Osc. anode	85	5
3	AC/VP2	Anode ..	245	11
		Screen ..	245	1.8
4	AC/HL/DD	Anode ..	60	1
5	AC5/Pen.	Anode ..	235	34
		Screen ..	245	5.8
6	U4	Heater ..	380	—

Alignment Notes

I.F. Circuits.—The I.F. transformers should not be adjusted as they are of the driftless iron core type. However, replacement of one or both of the I.F. transformers will call for the following procedure.

Connect an output meter across the primary of the speaker transformer and a service oscillator between the top grid cap of V2 and chassis. Switch set to M.W. band, turn gang to maximum capacity. Turn volume to maximum and tone to "high."

Tune service oscillator to 465 kc. and adjust the iron cores of I.F.T.2 and then I.F.T.1 for maximum, reducing the input as the circuits come into line. Use a non-metallic trimming tool for this operation.

Signal circuits.—Connect the service oscillator to the aerial and earth sockets only feeding sufficient input to obtain reliable peaks in the output meter and reducing the input as the circuits come into line.

With gang at maximum capacity the pointer should coincide with 180 degrees on the dial marking.

Long Waves.—Tune set and oscillator to 1,304 metres (231kc.) and adjust T1, T2 and then T3 for maximum.

Tune set and oscillator to 1,875 metres (160 kc.) and adjust P1 for maximum, simultaneously rocking the gang.

Repeat both operations until no further improvement results.

Medium Waves.—Tune set and oscillator to 250 metres (1,200 kc.) and adjust T4 for maximum.

Tune set and oscillator to 531 metres (565 kc.) and adjust P2 for maximum, simultaneously rocking the gang.

Return to 250 metres, readjust T4 and then readjust P2 on a 531 metres signal. Then feed in a 350 metres (856 kc.)

(Continued on page 25.)

Ambassador 6778 on Test

MODEL 6778.—For A.C. mains, 200-250 volts, 40-100 cycles. Price, 12 gns.

DESCRIPTION.—Five-valve, plus rectifier four-band table model.

FEATURES.—Full vision scale calibrated in metres and station names and coloured as to wavebands. Wavelength pointer has two arms, between which the name of the station tuned in is seen. Controls for tuning, combined volume and master switch, tone and wave selection. Speaker at side of chassis. Separate power pack chassis. Sockets for pick-up. Low impedance extra speaker connection.

LOADING.—72 watts.

Sensitivity and Selectivity

SHORT WAVES (12-35 and 34-96 metres).—Excellent gain and good selectivity with easy handling and no drift.

MEDIUM WAVES (200-550 metres).—Good gain and excellent selectivity with reasonably quiet background.

LONG WAVES (800-2,000 metres).—Good gain and selectivity, with all main stations easily received.

Acoustic Output

Ample volume for a large room, with crisp, clean attack and good medium and low note radiation. Speech is free from marked colouration and orchestral balance is very pleasing.

RESISTANCES

R.	Purpose.	Ohms.
1	V1 A.V.C. decoupling	500,000
2	V1 cathode bias	150
3	V2 A.V.C. decoupling	500,000
4	V2 screen potr. (part)	20,000
5	V2 screen potr. (part)	30,000
6	V2 series grid	50
7	V2 cathode bias	150
8	Osc. anode load	80,000
9	Osc. grid leak	50,000
10	V3 A.V.C. decoupling	500,000
11	V3 cathode bias	150
12	V3 anode decoupling	1,000
13	H.F. stopper	50,000
14	Volume control	1 meg.
15	V4 anode load	250,000
16	Tone control	500,000
17	V5 grid stopper	50,000
18	V5 cathode bias (part)	50
19	V5 cathode bias (part)	120
20	Regeneration modifier	150
21	Regeneration modifier	150
22	V4 grid stopper	50,000
23	V4 diodes, load	500,000
24	V4 diodes, load	500,000

QUICK TESTS

Quick tests are available on the leads to the speaker panel. Voltages between these and the chassis should be:—

- Red lead, 245 volts, unsmoothed H.T.
- Blue lead, 235 volts, smoothed H.T.
- Yellow lead, 330 volts, smoothed H.T.

CONDENSERS

C.	Purpose.	Mfds.
1	V1 A.V.C. decoupling	.1
2	Aerial switch shunting	.01
3	V1 cathode bias shunt	.1
4	H.T. line by-pass	.1
5	V2 A.V.C. decoupling	.1
6	H.F. switch shunting	.01
7	V2 screen decoupling	.1
8	V2 cathode bias shunt	.1
9	Osc. grid	.0001
10	Osc. anode coupling	.001
11	S.W.1 fixed padder	.005
12	S.W.2 fixed padder	.024
13	M.W. fixed padder	.0005
17	V3 A.V.C. decoupling	.1
18	V3 cathode bias shunt	.1
19	V3 anode decoupling	.1
22	H.F. by-pass	.0001
23	H.F. by-pass	.0002
24	L.F. coupling	.01
25	Tone control	.01
26	V4 anode shunt	.0005
27	L.F. coupling	.1
28	V5 cathode bias shunt	50
29	Pentode compensator	.01
30	H.T. line by-pass	.01
31	H.T. smoothing	.16
32	H.T. smoothing	.16

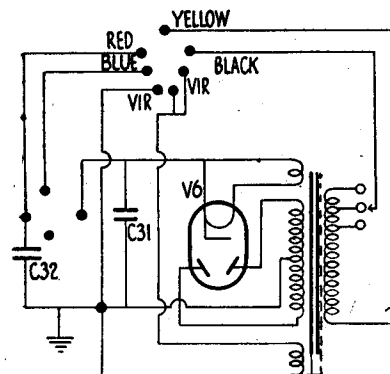
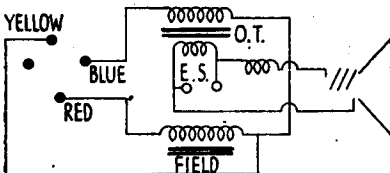

Separate power pack and speaker assembly sections are features of the Ambassador 6778 design. Top is the speaker unit circuit, and below that of the power pack.

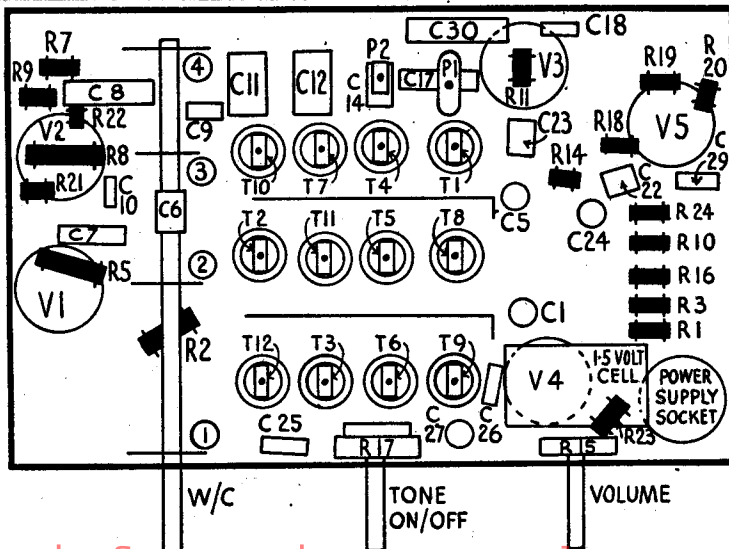
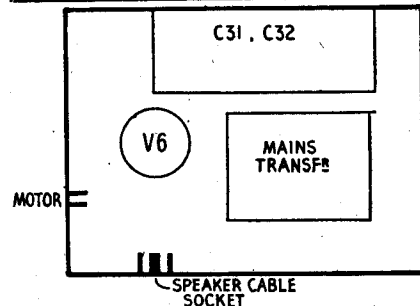

Left is the underside view of the chassis of the Ambassador 6778 showing the simple lay-out of the components. Above is a similar drawing of the power pack chassis.